

Issue 1, First Quarter 2007

Agilent Measurement Journal

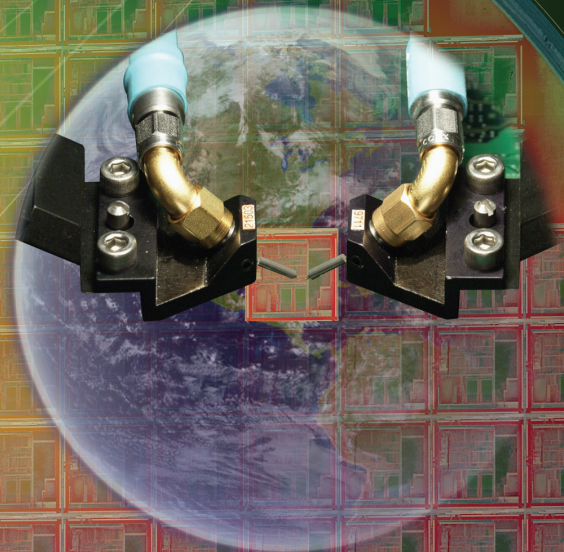

Agilent Technologies

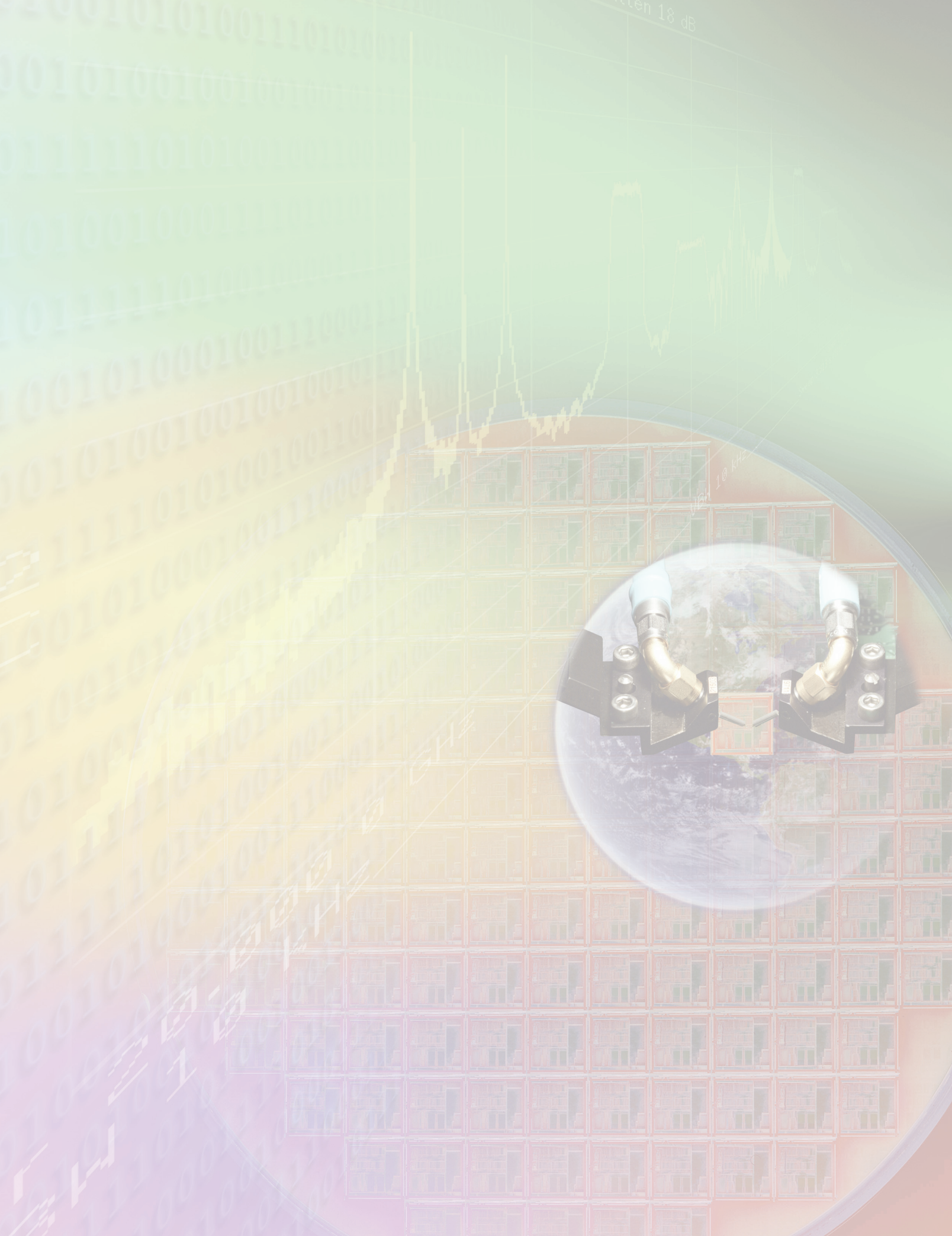

A New Resource to Help Meet Your Challenges Today and Tomorrow

Technology development and commercialization has never been more challenging than it is today. New products, destined to play in a global market, must be developed more quickly and cost effectively, with fewer resources and often times, in the face of demanding and changing requirements. Manufacturing and service provision must be done with the highest quality and with ever-present cost pressures. Complicating matters further, the electronics value chain now extends around the world. Despite these challenges, significant opportunities for innovation abound; particularly in the mobile devices and services, digital entertainment and security markets, just to name a few. But how can you best capture these opportunities while dealing with the many challenges you now face?



As the world's premier measurement company, Agilent Technologies is firmly committed to being a measurement solutions partner to every engineer, scientist and service provider in the world today. We know that a trusted resource can help you better understand and prepare for the impact of new technologies. This is where the new *Agilent Measurement Journal* — specifically focused on the application of measurement technology to emerging and challenging technology development and commercialization — comes in. Each

quarter our journal will provide you with a range of technical articles, information regarding industry and technology trends and analysis, and valuable reference materials. From it you will also gain a firsthand look at Agilent's ongoing research and development, collaborations with market-leading customers, industry-leading technology, new product introductions, and product updates.

The *Agilent Measurement Journal* is an indispensable reference tool designed to help you learn new engineering techniques, find ways to more quickly and economically build products and make informed decisions. Our goal is that you will read its articles, with urgency, to gain timely insight into the markets in which you work and more importantly, that you will keep it for future reference and lasting value.

Welcome to the *Agilent Measurement Journal*!

A handwritten signature in black ink that reads "Patrick Byrne".

Patrick J. Byrne

Agilent Technologies Senior Vice President
President, Electronic Measurements Group

42 Innovations Department

Agilent MXG — Signal Generation Technology Reaches New Heights

The new Agilent MXG signal generators have made significant technical contributions to the test and measurement industry. Read about the technical breakthroughs that have made it possible.

54 Agilent Inside Department

Agilent's Advanced High-Frequency IC Technology

Proprietary high-frequency ICs, packaging, and models enable premier measurement capability and innovation.

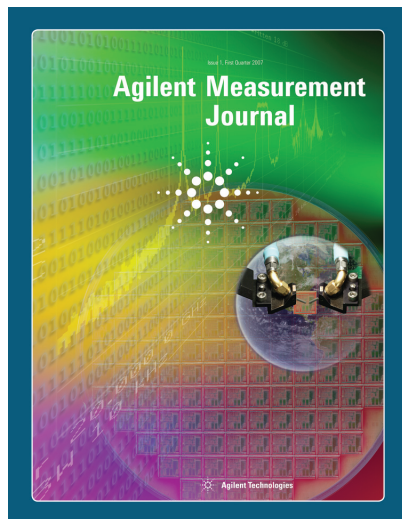

www.agilent.com/go/journal

1

Welcome

An introduction to the *Agilent Measurement Journal* by Patrick J. Byrne.

4

Innovation That Helps Agilent Customers Achieve Business Success

Interview with Darlene J.S. Solomon of Agilent Laboratories.



8

Innovation in Measurement:

How the dynamics of the electronics industry are leading to measurement innovation.



14 LXI and The New Generation of Automated Test

Using LXI results in smaller, less expensive test systems. Here are some of the factors that drive the development of networked instruments and how they are used in test systems.

20 How to Set Up an LXI System

Setting up a networked test system is as easy as following these guidelines.

24 Using Precision Time Protocol with LXI

Precision time protocol is one of the most intriguing features of LXI. Learn how it works and how you can apply this important new standard.

28 Measuring Oscilloscope Sampling Fidelity

High sample rates do not always produce the most accurate measurements — sampling fidelity is just as important.

34 Analog-to-Digital Converters

How oscilloscope analog-to-digital converter's architectures have been optimized over the past two decades.

41 Collaborating to Create a New Laboratory

Agilent Technologies joins Philips and Cascade Microtech to create a new Electronic Measurement Laboratory at High Tech Campus Eindhoven.



48 The Evolution of RF/Microwave Network Analyzers

The evolution of the RF/microwave network analyzer has enabled the evolution of high frequency components and how they are designed.

58 Spread-Spectrum Clocking: Measuring the Downslope Accuracy and Depth

This method measures accuracy while eliminating too much EMI within any one band and reducing cross-talk.

62 Choosing Power Supplies for Maximum ATE System Flexibility

ATE system designers are challenged by two goals that oppose one another: improve ATE system flexibility and keep ATE system costs down.

66 Using IVI-COM: The Top Ten Things You Need to Know

The Interchangeable Virtual Instruments-Component Object Model (IVI-COM) specification is the latest standard to emerge for instrument drivers.

74 Agilent Labs Awards Innovation Prize

Agilent Laboratories awards 2006 Barney Oliver Prize for Innovation to retired Agilent Fellow Nick Moll.

AGILENT MEASUREMENT JOURNAL

William P. Sullivan | President
and Chief Executive Officer

Darlene J.S. Solomon | Agilent
Chief Technology Officer and Vice President,
Agilent Laboratories

Patrick J. Byrne | Agilent Technologies
Senior Vice President
President, Electronic Measurements Group

Chris van Ingen | President
Life Sciences and Chemical Analysis

Heidi Garcia | Editor-in-Chief

ADVISORY BOARD

David Badtorff | San Diego, California, USA

Lee Barford | Santa Clara, California, USA

Bert Esser | Amstelveen, Netherlands

Johnnie Hancock | Colorado Springs,
Colorado, USA

Theresa Khoo | Singapore, Singapore

Jean-Claude Krynicki | Palaiseau, Essonne,
France

Yat Por Lau | Penang, Malaysia

Rick Laurell | Santa Rosa, California, USA

Craig Schmidt | Loveland, Colorado, USA

Roger Stancliff | Santa Rosa, California, USA

Kazuyuki Tamaru | Tokyo, Japan

Boon-Khim Tan | Penang, Malaysia

Daniel Thomasson | Santa Rosa, California, USA

Rory Van Tuyl | Santa Clara, California, USA

Kenn Wildnauer | Santa Rosa, California, USA

EDITORIAL

Please e-mail inquiries and requests to
journal@agilent.com

Agilent Measurement Journal

Innovation That Helps Agilent Customers Achieve Business Success

Interview with
Darlene J.S. Solomon
of Agilent Laboratories



Research and development today remains the key means by which industry can ensure the successful development and commercialization of innovative new technologies. As a world-leading industrial research center, Agilent Laboratories takes that role seriously as it works to identify new and emerging trends and uncover the challenges that those trends present. Through a company-wide collaborative effort, Agilent Labs partners with the appropriate Agilent business units to innovate the technology necessary to

solve those challenges. That technology ultimately forms the basis of leading-edge solutions that make their way to market to help Agilent's customers achieve business success. With its well-established approach to collaborative research and development, and strong relationships with academia, industrial partners, customers and standards bodies, Agilent Labs is today not just researching the future — it is helping to create it.

A closer look at Agilent Labs

Agilent Measurement Journal recently sat down with Darlene J.S. Solomon, Agilent chief technology officer and vice president of Agilent Laboratories, to discuss key industry trends and Agilent Labs' role in addressing those trends. Her answers provide thoughtful insight into the continued commitment by Agilent to remain at the forefront of worldwide research efforts. Here is a look at that discussion.

Journal: What key technology trends are driving the electronics industry today?

Darlene: There are several major trends that we have identified that relate to electronic measurement:

- Our customers need faster and less invasive measurements. These days, the electrical and optical signals that our customers want to measure have increasingly higher frequency content. Speed is very important because total measurement time one way or another translates into customer cost. In addition, minimally-invasive probing and signal acquisition mean more efficient and more accurate measurements.
- The growing availability of high performance data converters leads to greater digital content in all kinds of measurement solutions. Agilent is driving this trend, which increases the volume of digital data and highlights the growing importance of digital signal processing and data management in electronic measurement solutions.
- The trend toward increased integration of measurement science domain knowledge, algorithms and modeling into measurement solutions is based on the need to provide customers with clear and actionable information — not just a set of spectra or numbers.
- Also, the convergence of communications and measurement network technologies enables new capabilities. For example, putting measurement intelligence into cell phones could help telecommunications network providers to shift their focus beyond network assurance to new quality levels for customer assurance.
- The emergence of modular architectures for instruments and sensors is meeting customer needs for smaller size, more flexibility and lower cost of ownership. These are important needs across many industries, a key example being aerospace and defense.

Journal: What's happening beyond electronics as we know that field today?

Darlene: Stepping back, disruptive technology breakthroughs continue to generate new market waves and illustrate the need for on-going innovation to stay at the leading edge (see Figure 1). Over the years, Hewlett-Packard and Agilent Technologies have done well through these waves. For example, the transistor and integrated circuits were key technologies leading the company's roots as a test and measurement company in the 1950s; computational devices and the personal computer fueled the electronics and computer wave, followed by the invention of low-cost lasers and fiber optic components, which enabled the communication/internet wave. Today, with innovations like recombinant DNA technology and the sequencing of the human genome, we find ourselves in the heart of the biotechnology revolution and poised on the cusp of the next wave of nanotechnology and bioelectronics.

To achieve high growth, companies must ride these waves with success, and organizations like Agilent must continually reinvent themselves. We can't afford to just keep doing what we've always done, but reinvention is difficult. It's especially challenging in large and successful companies to look beyond existing markets and anticipate new and disruptive technologies. But reinvention and innovation by themselves won't enable growth. We have to be willing and able to evolve with the technology cycles, anticipate where they're going, make bets about the direction of a specific technology and follow through with those bets.

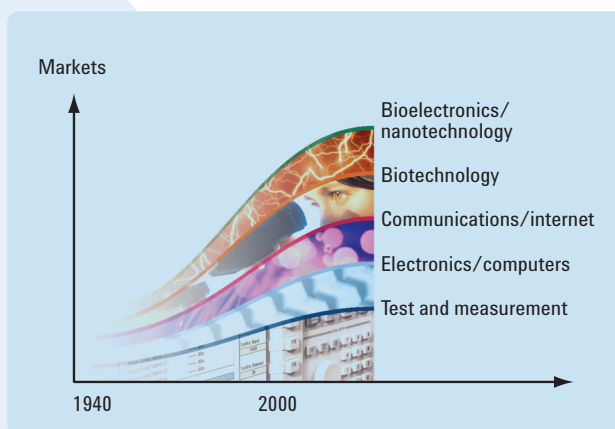

Figure 1. This graphic depicts waves of disruptive technologies.

Journal: What is the role of Agilent Labs in addressing these trends?

Darlene: Labs' research focuses on breakthroughs in measurement that represent orders-of-magnitude changes of tens, hundreds and on occasion, even thousands of times improvement over current technologies. To realize the potential of a new technology wave, new measurements are often needed. Measurement availability directly impacts the kinds of questions engineers and scientists can ask; in a sense, measurement drives innovation.

For example, in biotechnology, technologies are now well-established to sequence proteins and to measure protein-protein interactions. Technologies are not readily available, however, to study the interaction of these proteins with very small drug molecules, or to study subtle differences in protein modification that relate directly to how proteins are recognized inside our bodies. Similarly, in advancing nanotechnology, nanoparticles are often key enablers of new material properties. Technologies exist to understand the physical properties of particle mixtures at the micron scale, but the ability to reproducibly measure the size and distribution of a heterogeneous solution of nanoparticles is a difficult challenge.

Agilent Labs and Agilent's business units work very closely together to understand evolving market conditions and technology waves. That collaboration takes place formally and informally across all levels of the company and enables researchers to recognize and exploit problem-solving opportunities that can be created through synthesis of seemingly unrelated technologies. We strive to understand the problems that matter most for Agilent's customers and provide innovative measurement solutions to address them.

Journal: In addition to providing innovative breakthrough technologies for products, how does Agilent Labs contribute to Agilent?

Darlene: Agilent Labs contributes in a number of ways to Agilent's overall success. The researchers at Agilent Labs scan the industry for emerging business opportunities and the most promising technologies. Our people stay connected with the global academic research network and the venture capital community. They also participate as active members of numerous centers of excellence, such as academic and government-sponsored technology advisory, standards and editorial boards.

Members of the Labs staff routinely consult, for example, with Agilent management on annual strategic plans and with manufacturing teams when their expertise can address significant issues. Labs helps evaluate potential technology investments and supports Agilent in technology assessments and valuations for mergers and acquisitions. And Labs accounts for roughly one-third of all patents granted to the company each year.

Journal: What are some examples of successful technology developed at Agilent Labs that have had a significant impact on industry?

Darlene: While there are many examples, I'll mention four technology developments that highlight Agilent's ongoing impact on the industry:

World's fastest CMOS analog-to-digital converters (ADCs)

Agilent Labs developed ADCs that provide speed and precision gains with an innovative approach using the slower, less accurate CMOS technology (see Figure 2). Commercialized by our partners in Agilent's Electronic Measurements Group, the first chip that resulted from this development was one-third the cost and one-third the power of traditional bipolar technology, yet equivalent in sampling performance. The second chip garnered attention as the world's fastest 8-bit ADC. ADCs enable the highest-performance Agilent instruments by converting high speed signals from analog waveforms to digital bits for computer analysis. Today, Agilent is continuing to extend the performance of this disruptive technology.

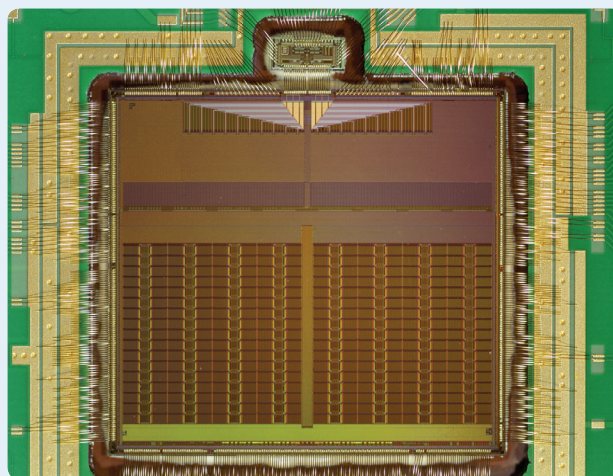

Figure 2. Shown here is Agilent's first breakthrough analog-to-digital converter IC. Agilent ADCs enable the creation of measurement instruments with industry-leading performance.

Arbitrary waveform generator

Simulating real-world radar signals, Agilent's N6030A arbitrary waveform generator (AWG) combines bandwidth and spurious-free dynamic range with the most advanced memory sequencings—far out pacing the nearest competitor — and a thousand-fold increase in accuracy. Labs developed a digital-to-analog converter that's a key component at the heart of the AWG, commercialized by our partners in Agilent's Electronic Measurements Group. The chip converts signals from the digital to the analog domain. The Agilent AWG saves time and reduces costs for design engineers working on next-generation communications and electronic systems.

Next-generation test capabilities

Agilent provides next-generation test capabilities that enable customers to design modular test systems quickly and easily. A prime example is Labs' technology developments in precision time measurement and synchronization, and ongoing support for the LAN eXtensions for Instruments (LXI) IEEE standard. Backed by Agilent and a consortium of companies, LXI defines smaller, modular instruments using low-cost, open-standard LAN (e.g. Ethernet) as the system backbone. Its main benefits include flexibility, scalability and the convenience of plug-and-play instruments.

HBT IC process

Labs' pioneering work resulted in a new semiconductor III-V technology and manufacturing process based on indium phosphide heterostructure bipolar transistor (HBT). The outcome of the Labs' research and collaboration with Agilent's Electronic Measurements Group has been the development of an extremely high-performance, world-leading technology that can enable our test and measurement products to go to higher frequencies while also maintaining voltage and output power levels. These HBTs have emerged as the world leaders in digital circuits speed and in mixed signal and microwave/mm-wave systems. Customers directly benefit from this technology because many Agilent instruments take advantage of the design efficiency, increased performance and reliability, lower cost, and advanced features provided by this remarkable technology. And the technology gives Agilent an advantage because we are not limited to the same off-the-shelf integrated circuits that our competitors use.

Journal: Where is Labs located?

Darlene: Agilent Labs has R&D efforts strategically distributed around the world with Agilent businesses. Labs research sites located in Santa Clara, California; Everett, Washington; South Queensferry, Scotland; Brussels, Belgium; and Beijing, China, facilitate open innovation in research conducted in advance of market need.

For example, Labs' strong European R&D presence provides opportunities to participate with European research organizations, universities and innovative European companies in research related to emerging telecommunications standards. Because of this involvement, Agilent is better able to develop test and measurement equipment to address issues such as emerging air interfaces. In turn, the early availability of Agilent's advanced signal generators and analyzers helps accelerate wireless terminal/handset development in Europe.

Journal: How does Agilent manage its investments in R&D?

Darlene: Agilent is committed company-wide to innovation and invests roughly 10 to 14 percent of annual revenue in R&D, depending on the business cycle. In 2006, that investment amounted to approximately \$600 million. More than 90 percent of Agilent R&D takes place in business units in support of product development in electronic and bio-analytical measurement, typically within three years of product introduction. Agilent Laboratories focuses the remaining R&D on longer range, higher-risk research in the three- to 10-year time frame.

Journal: How do people at Labs work with researchers in Agilent's businesses?

Darlene: Our work at Agilent Labs is to innovate breakthrough technologies that enable a steady flow of revolutionary new products and solutions to customers. All of the technologies that support Agilent's existing and emerging businesses come together in Agilent Labs, and Labs researchers are committed to strong collaborative relationships that leverage their broad technology base. Focusing on the intersection of technology contribution and customer value, they successfully partner with Agilent businesses — as well as with customers, other research organizations and universities. Labs creates a research environment that supports risk-taking, fosters team work and allows for expertise and input from multiple disciplines in questioning the status-quo.

While many companies have struggled in recent years with the charter and mission of their central research organizations, Agilent Labs has remained a vital part of the company. Fundamental to Labs' contributions are the deep core competences of our technical staff in their broad range of science and engineering disciplines and their honed capability and priority in transferring breakthrough technologies to Agilent's businesses that create business value for our customers.



Innovation in Measurement:

How the dynamics of the
electronics industry are
leading to measurement
innovation

Patrick J. Byrne

*Agilent Technologies Senior Vice President
President, Electronic Measurements Group*

It is this type of *collaborative innovation* effort — working together with market-making companies around the world — that is today redefining the world of technology commercialization. But what does that mean for the world's premier measurement company, Agilent Technologies? What role will it play in enabling this vision of a new world? More importantly, what is the company doing today and for the future to promote the successful commercialization of new technology? Let's take a closer look.

T

The world today is both small and big. It is small because advanced technology has become so personal and available. Digital entertainment and communication is everywhere and available to billions of people personally, worldwide. Neighborhoods are comprised of wireless networks and even the most obscure songs and books are purchased at least once a quarter on the Internet. As evidence of this, just take a quick look at the variety of songs by different musicians that have been downloaded onto the average teenager's iPod. By the same token, the world is very big because the work that is done to create and rapidly commercialize these technologies is a global enterprise. Here, money flows freely to the best ideas, technologies, and teams with the best organizational capabilities with lightning speed, ignoring all traditional boundaries.

This is the world in which we now live. A world that is increasingly defined by any time, any place connectivity. A decade ago such mobility would have seemed inconceivable, yet today it comes easily thanks to a wide array of mobile devices incorporating a range of new and emerging wireless standards. More and more that connectivity is enabling communication on a global scale and creating what many refer to as a "flat" world. I see this every time I travel: visiting start-up companies in Israel for example. There I witnessed first hand, how a chip company in Tel Aviv was working with equipment manufacturers and service providers in Europe and the United States to develop and commercialize new wireless networking technology in record time. Manufacturing will be done through new product development centers in Asia and production will take place in every continent with the majority being done in Asia where the economics are compelling.

30-year trends

While the comments I have made thus far are anecdotal, they are indicative of well-documented industry trends regarding mobility, the global marketplace and security. Trends like these often take 30 years to play out and along the way transform the industry. Measurement is a derivative industry and a compelling enabler of such trends. It provides the assurance, quality and data sources for this technology development and commercialization. As new technology is developed, measurement will be vital to sustaining innovation.

Mobility

The expectation of pervasive and ubiquitous mobility has been created by the mobile phone and service telecommunications industry revolution. Today, nearly 2 billion people use mobile phones daily. That proliferation has created two important market trends in mobile phones. One trend is that mobile phone costs are declining to meet the needs of the emerging economies. This reduction is driving all suppliers in the mobile phone value chain to innovate with cost-effective solutions. Another trend goes the other way — higher functionality. This drives the speed and utility of the mobile data-centric Internet. This has been bolstered by recent developments in worldwide spectrum allocation and standardization of emerging wireless communications protocols such as EVDO, 802.11, HSDPA/HSUPA, WiMAX, and ZigBee. Currently, China has the highest use of wireless technologies, closely followed by the European Union and the United States. These trends represent a global technology movement and the solutions must be addressed with a global capability and deployment.

This continuing adoption of wireless technologies is today creating opportunities in device, terminal, network, and service and application innovation. In other words — it's not just about mobile phones anymore. The laptop, RFID tags, and telematics in automobiles are all examples of platforms that have and will continue to benefit from the power of pervasive mobility. In automobiles for example, the electronics innovation is driving operating margins. Wireless, GPS and infotainment will combine in the next decade for exciting new products and services. In the defense arena, this mobility is leading to the next-generation of battlefield engagements — a network-centric warfare model based on commercial off-the-shelf technologies (COTS).

Fast growing economies

China, with its large population and area, today represents the largest market of any developing country in the world. It ranks as the third-largest research and development market in the world and is expected to move up to number two, behind the United States, within the next five years. Its \$200 billion electronics industry alone is growing at roughly 20 percent each year. This growth is in part driven by China's motivated and educated workforce, as well as pent-up demand for technological contributions, and is creating many opportunities for new technology development and innovation.

But it's not just China. Many Asian economies are growing at around 10 percent per year. India also is growing — currently adding roughly five million new mobile phone subscribers each month. Many of these countries have young and growing populations who will define the future use cases and opportunities for technology. Eastern Europe is a prime example. Here there is a highly-educated and motivated, young workforce looking to make a contribution while enjoying the benefits of these new technologies.

Global security and defense

When it comes to security, the world has undergone a dramatic change in the last five to ten years. In the United States, for example, 9/11 was the defining event, but the war on terror and the compelling need for people everywhere to feel secure about themselves and their countries is global. Using an all-IP network with pervasive mobility to defend security is now a top priority for governments of the world. Surveillance technology will be used to manage the network-centric battlefield as well as Homeland Security applications (Figure 1). The expectation is that commercialization of advanced technologies will save people's lives at home and on the battlefield. In fact though, those technologies are designed to help avoid the battlefield.

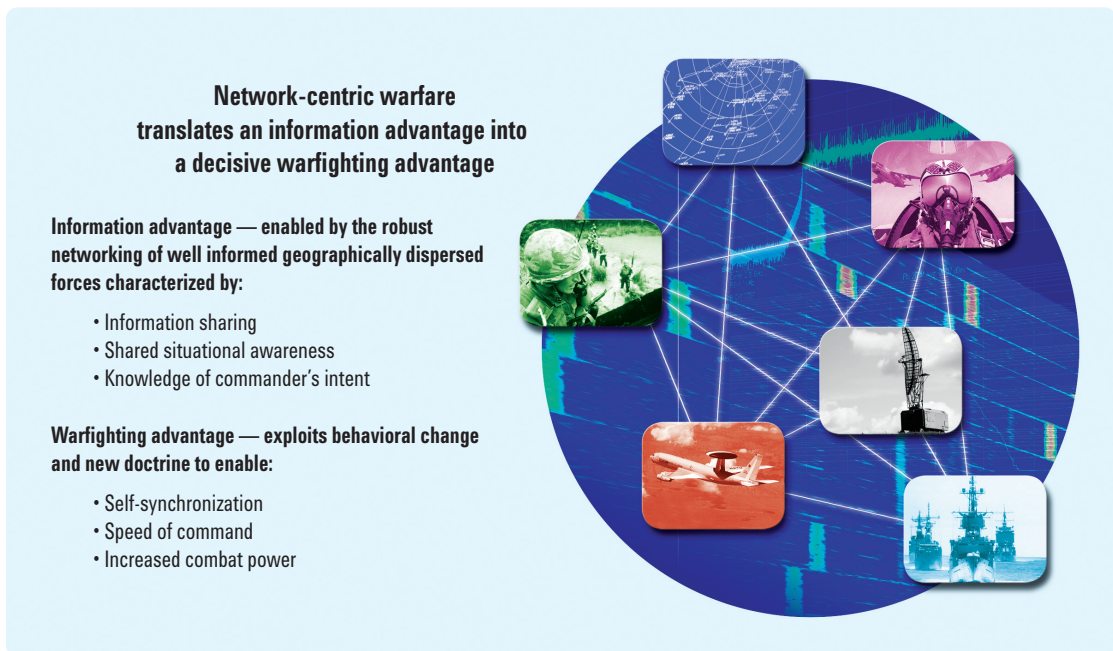

Figure 1. Network-centric warfare is an emerging theory of war pioneered by the United States Department of Defense. It seeks to translate an information advantage into a competitive warfighting advantage through the robust networking of well-informed geographically dispersed forces.

Microwave energy weapons, robotics, space-based radar, and broadband surveillance are all examples of just such advanced technologies which promise to leave a lasting mark in the service of security.

Industry leadership: World's premier measurement company

While these trends create a range of new business opportunities on the global market, they also lead to some compelling new challenges throughout the entire product lifecycle. Keeping pace with emerging applications and technologies in light of shrinking design cycles and time-to-market schedules is just one concern. Decreasing a product's design, manufacturing and test cost, while increasing its performance, functionality and quality is yet another concern. These challenges will only increase in coming years, as the speed of technological development and innovation continues to increase.

Measurement companies play a critical role in advancing the simultaneous progress on all these fronts. That's because measurement is a derivative industry charged with the task of enabling emerging industries and supporting technology commercialization within those industries. It follows therefore, that new measurement solutions will need to be developed alongside new technology development and commercialization.

This must be done as a collaborative innovation effort to avoid the time and cost associated with separate innovation paths. Consequently, today's premier measurement company must embody exceptional global collaboration and be able to work as an innovation partner with industry market makers — defining customers, research institutes, standards bodies, and universities — to accelerate progress and reduce risk. It must be a catalyst and enabler of innovation, as well as a technology resource and repository of specialized expertise. And, as new measurement requirements emerge as solution categories, the premier measurement company must create robust standard products, services and applications in support of the complete product lifecycle for its customers.

Agilent Technologies:

The world's premier measurement company

Based on more than 60 years of measurement innovation that originated in Hewlett-Packard, Agilent Technologies today stands as the world's premier measurement company. By bringing new products to market faster, improving quality, reducing cost, enabling services, advancing research priorities, and improving manufacturing operations, we are the measurement solutions partner to every engineer, scientist and service provider in the world.

Collaborative innovation

Collaborative innovation will accelerate progress in our industries. The new *Agilent Measurement Journal* is an example of that innovation and of how Agilent is using its technical expertise to address current and emerging measurement requirements.

Some of the other ways in which Agilent is working to address today's measurement needs include the following:

Mobility

Agilent Technologies continues to be at the forefront of the emerging wireless communications and mobility markets, with its measurement solutions specifically optimized for testing applications based on emerging wireless standards (Figure 2). With regard to WiMAX, for example, Agilent offers solutions which span the entire WiMAX lifecycle — from R&D and design verification to manufacturing, conformance and interoperability test. A member of the WiMAX Forum since September 2004, Agilent is an active participant in the development of WiMAX Radio Conformance Tests (RCT). It was first to provide standard-compliant 802.16 design and test tools for fixed and mobile WiMAX applications, and the first to enable RF and baseband engineers working at the 802.16-2004 PHY layer to create, analyze and troubleshoot signals. Agilent is now extending its expertise into manufacturing, as well as fostering the strategic partnerships necessary, such as with AT4 Wireless, to continue bringing innovative WiMAX solutions to market.

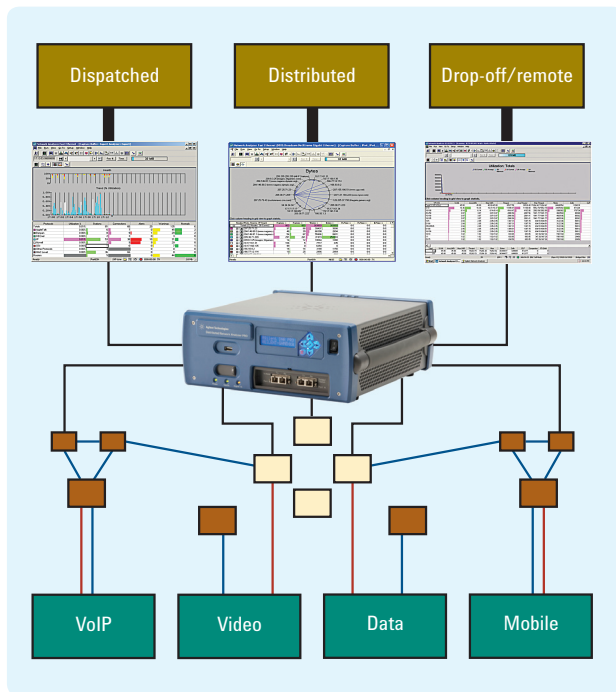

Figure 2. Network convergence into an all IP infrastructure enables new services such as VoIP and IPTV but also creates new test challenges. The new Agilent J6900A triple play analyzer integrates the testing of converged networks in a single platform and which greatly simplifies the troubleshooting process.

Agilent's work with WiMAX is an exceptional example of industry-based collaborative innovation. It clearly demonstrates our ability to take emerging wireless communications requirements and standards, which have been commercialized into robust standard products and applications, and turn them into cost effective measurement solutions of the highest possible quality. The new Agilent MXA signal analyzer and MXG analog and vector signal generators are the latest examples of that capability (Figure 3).

Fast growing economies

Agilent is present in the fastest growing local economies with the best local support and global reach. A prime example of this global reach is in India — a country which has recently emerged as a fast growing wireless economy with a rich heritage of innovation in electronics development. Agilent has been in India for many years and provides the very best local support and development collaboration in electronics measurement, as well as in life sciences and chemical analysis.

As another example of Agilent's global reach, consider the evolution of Agilent Technologies China. It began in 1999 with the start of our company after the spin-off from Hewlett-Packard. Over the next several years, it built strong wireless and chemical analysis R&D and support centers in China and Korea, and in 2005 formed a joint venture with Quinfeng Electronics in Chengdu. This joint venture, along with our strong Asia-based R&D teams throughout the region, are creating exciting products specifically designed to meet Asia market requirements while also supporting global needs.

Today, Agilent has the largest Asia-based team of any measurement company in the industry, by far. This is our commitment to support collaborative innovation with our customers and partners. That commitment extends beyond Asia to include all the growing technology economies around the world. Our recent opening of R&D centers in Tel Aviv, Israel and Geneva, Switzerland are just two further examples of our commitment to growing with the technology centers of innovation.

Global security and defense

Agilent is focused on supporting the orderly upgrade — often called re-capitalization in the United States — of the aerospace and defense industry to update older equipment. It is also dedicated to accelerating innovations in signal monitoring, interception, and surveillance — all of which rely heavily on the use of microwave and broadband measurement technologies.

As the leading provider of measurement instrumentation to the aerospace and defense industry, Agilent provides the tools required to keep equipment operating at peak effectiveness across the field of electronics and around the globe. Its unique breadth of experience and solutions address the needs of engineers throughout the product lifecycle, from design and manufacturing to performance verification and maintenance and depot repair. The lifecycle support model in this industry requires a long-term commitment to technology insertion strategies and must be done in collaboration with the industry market makers, in government and industry.

One more: The LXI innovation

Agilent is a leader in the next generation of test system architectural innovation. This is based on the new standard; LXI (LAN eXtensions for Instruments). Agilent was instrumental in the creation of the LXI Consortium in 2004, a not-for-profit corporation made up of leading test and measurement companies (totaling 43 industry members to date) working to develop, support and promote the LXI standard. And, through its work with LXI, Agilent is defining a new generation of low-cost reconfigurable synthetic instruments which can be customized to fit application requirements. Consequently, LXI is a prime example of collaborative innovation between our customers, partners, and competitors for the benefit of the industry.

Agilent is committed, on a long term basis, to LXI and to the compliance of our electronics measurement products to that standard. Doing so will allow us to foster industry innovation based on a common, open and stable architecture.

As the successor to GPIB (IEEE standard), LXI combines the advantages of Ethernet with the simplicity and familiarity of GPIB. Its compact, flexible package, high-speed I/O and prolific use of LAN enables it to address the needs of aerospace defense engineers developing radar, electronic warfare, satellite and military communications systems, as well as a broad range of industrial and commercial applications. As a leader in LXI development and adoption, Agilent now offers over 75 LXI-compliant solutions. Through its continued support of the LXI industry con-

sortium, Agilent is leading a change in the way the industry thinks about measurement solutions. In fact, several of the articles in this inaugural issue of the *Agilent Measurement Journal* outline the LXI innovation.

Our future together

Innovation is accelerating in a small world that is very big. Measurement will enable simultaneous progress toward rapid technology development and commercialization. The premier measurement company delivers this measurement capability with collaborative innovation. Doing so avoids delays and waste, while getting the best ideas and teams working together in real-time.

Today there are a number of powerful 30-year trends which are driving future measurement requirements, including pervasive mobility, fast growing global economies and the emergence of security and defense in a changed world. Agilent has and continues to demonstrate industry leadership in each of these and many other fields in electronics, life sciences and chemical analysis. We are a company driven by the spirit of collaborative innovation. We are committed to being the measurement solutions partner to every engineer, scientist and service provider in the world today.

The *Agilent Measurement Journal* has been created in service to this mission. Thank you for being our partner.

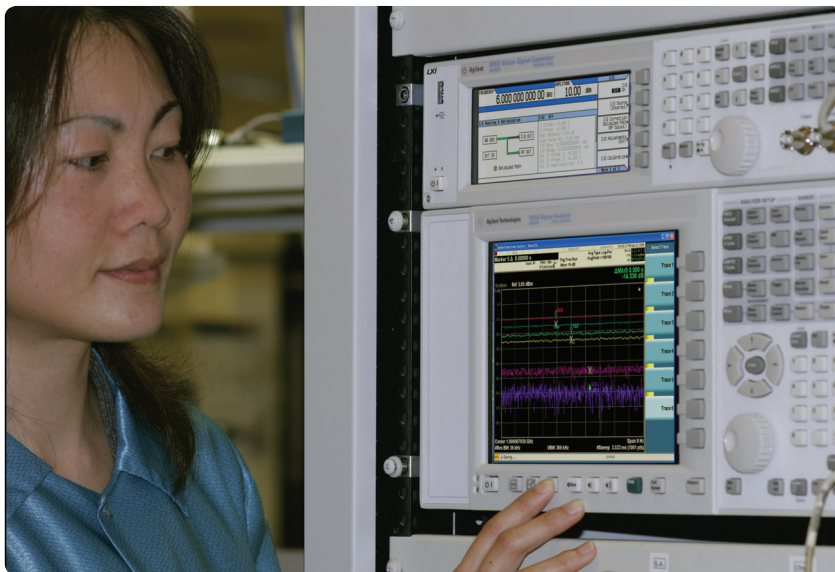

Figure 3. Agilent's new MXA signal analyzer provides the industry's highest performance in a midrange analyzer. The Agilent MXG is a mid-performance signal generator optimized for manufacturing applications in cellular communications and wireless connectivity systems.



LXI and the New Generation of Automated Test

**Understanding the technologies
that underlie LXI**

Christopher P. Kelly

Member of Technical Staff, Agilent Technologies
chris_kelly@agilent.com



Electronic test instruments have evolved over time, and the next generation has arrived. The LXI (LAN Extensions for Instrumentation) standard defines how these instruments appear and operate — the result is smaller, less expensive test systems that keep pace with advances in LAN communications technology. This article describes some of the factors that drive today's generation of instruments and how they are used in test systems.



Automated test — an historical perspective

In the 1960s, computers became smaller and more common and they began to be used to control test instruments, which made it possible for faster measurements than human operators could do alone. The connection between the instruments and computers exhibited a great deal of variation in the early years. In 1975 the IEEE 488 General Purpose Interface Bus (GPIB) standard was developed and has dominated the scene for several decades. This standard was specifically designed for operation of electronic instruments, and has served that function well.

It was soon clear that more was required than the standardization of the hardware interface. The instruments were physically compatible, but the instrument command languages varied greatly, and instrument control software was tied to certain instruments. In the 1990s the standards committees defined a language for instrument control to increase interchangeability. The IEEE 488.2 Standard and the Standard Commands for Programmable Instruments (SCPI) defined these commands.

About the same time, manufacturers defined VMEbus extensions for instrumentation (VXI), a compact high-speed instrument standard for high performance instruments which plugged into a card cage. This standard allows interoperable instruments to fit into a relatively small volume and to communicate directly with controlling computers using a wide backplane. The VXIbus allows the controllers or computers to plug into the same backplane as the instruments, tightly coupling them for high speed. In the year 2000, designers adapted the personal computer-based PCI bus to the concept of modular bus instrumentation and the result was the PXI (PCI Extensions for Instrumentation) bus.

In all of these standards, the connectivity to the computer is the primary factor, but other issues such as cost, size, media speed, and instrument performance also are major considerations. One of the fastest, simplest, and least expensive of the media used by computers today is the local area network (LAN). Ethernet LAN is ubiquitous with a vast infrastructure supporting connections worldwide. Constant investment in hardware and software has increased the speed three orders of magnitude and decreased the cost of a LAN installation in the last decade. Nearly every personal computer manufactured today is equipped with a LAN interface, and instruments can connect to this medium, with no extra costs associated with the connection hardware.

Agilent Technologies and VXI Technology seized an opportunity for electronic instruments to use this network and launched the LXI Consortium. Their mission is to grow beyond GPIB. One year after launch, the first version of the LXI Standard was released in September of 2005.

Components of the LXI standard

There are three LXI Classes with increasing levels of functionality from Class C to Class A instruments, as shown in Figure 1.

The LXI standard defines several design factors for instruments in addition to the LAN connection. Among these are a Web interface, peer-to-peer messaging, a wired trigger interface, a new distributed time-based triggering interface, and a software programming interface.

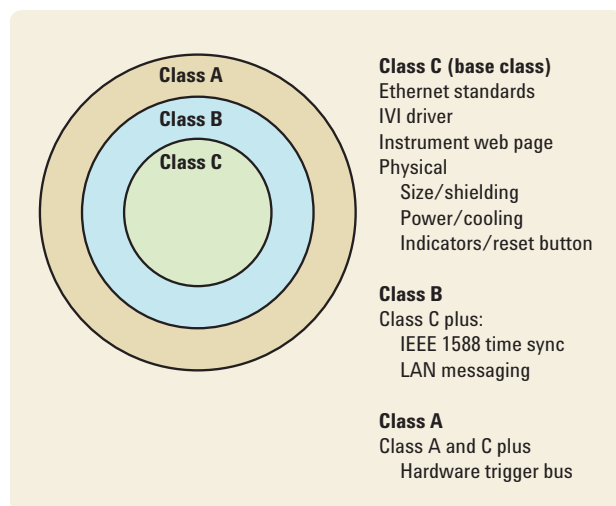

Figure 1. Basic LXI capability is provided by Class C instruments, with Class B and Class A instruments providing additional functionality.

The LAN interface

The connection to the instrument uses a standard LAN connector (RJ-45) that allows normal LAN cables to connect the instrument to PCs, switches, routers, and other LAN devices. Adopting this inexpensive computer standard interface does away with the need for custom interface cards, cables, and card cages used in other instrument standards. Wireless or fiber optic interfaces are easily connected where there are special needs.



Figure 2. A modular LXI instrument uses the RJ-45 LAN connector (blue wire) to communicate with a PC controller through an existing LAN infrastructure.

Connecting to an instrument requires only the IP address of the instrument. LXI allows for simple methods to define this address and identify the particular instrument at that address. The LAN address can be configured manually, or automatically, using standard techniques such as Dynamic Host Configuration Protocol (DHCP) or Auto-IP. Because the LXI instrument may have a very simple front panel, the specification calls for identification indicators on every instrument that make for rapid assurance of correct setup. The user can connect single or multiple instruments to the PC using cables and switches available at consumer stores. Though LXI is LAN-based (Ethernet), the standard allows hybrid systems composed of several types of instrument connections simultaneously, including LXI, GPIB, VXI, and PXI instruments.

The Web interface

Since a LAN connection allows internet-like instrument connection, the standard defines the Web page interface that allows any Web browser to connect to an LXI instrument to identify and configure LAN setup. Some instruments additionally allow the Web interface to control and monitor instrument operation as if it were using any page on the World Wide Web.

This interface allows the instrument itself to be designed with little or no front panel controls, because the Web page may actually present a more comprehensive human interface to an instrument than one built onto the instrument itself. Many LXI instruments still have full function front panels, but LXI makes it possible to design smaller and less expensive faceless instruments. Where instrument rack space is a major consideration, LXI instruments are often 1U, half-rack and can decrease measurement system size several-fold. In a systems application, the setup and testing of system operation is made simple using the Web interface, while later, test software suites can operate the instrument using much faster automated protocols.

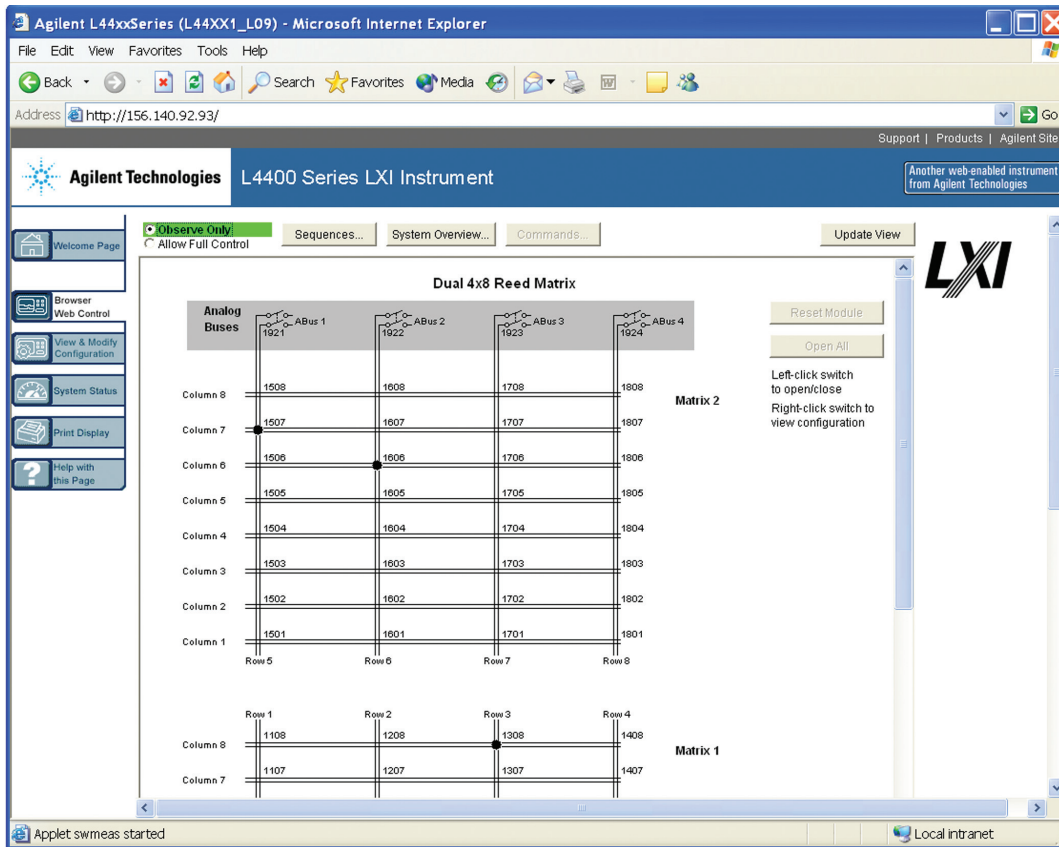

Figure 3. An LXI instrument serves up a Web page to any Web browser for simple setup or monitoring of instrument operation.

The trigger interfaces

Test and measurement systems achieve their speed and timing requirements by allowing fast coordination of instruments. The LXI bus allows trigger messages to be sent over the LAN interface, and also defines two trigger interfaces, one based on traditional wired connectors, and the other based upon the IEEE 1588 standard for LAN-based precision timing. The three methods provide a spectrum of cost versus performance.

The LAN triggering has capability similar to wired triggering, but extended to include peer-to-peer messaging between instruments, including multicast trigger packets. In this method, an instrument sends a trigger message to some or all other instruments at once over the LAN interface.

The wired trigger interface is designed to continue the availability of a commonly used feature of most of today's instruments. This ensures trigger speed for instruments that are located within a few meters of each other. This interface uses the fast low voltage differential signaling (LVDS) standard definition for the physical link layer.

The IEEE 1588 precision timing interface allows instrument events to occur with microsecond accuracy expected over a LAN (which does not have the trigger functions found in previous buses designed specifically for electronic test systems). Because each instrument has a clock closely synchronized to other instruments in the system, this interface allows instruments to be internally triggered at precise times. Instruments with the IEEE 1588 interface can both timestamp measurement events and initiate operations with microsecond precision. Test systems can thus maintain precise timing, even if the instruments are located some distance from each other.

These trigger interfaces allow the test instruments to capitalize on the LAN infrastructure for inexpensive connectivity while allowing the choice of additional speed and precision in systems that require them.

Software interface

While the Web interface is useful for setting up and troubleshooting a new test system, in automated operation the bulk of the instrument control actually occurs using the SCPI language or the Interchangeable Virtual Instrument (IVI) driver software. Both allow communication between the computer control program and the instruments. For example, a traditional test program written in the C language may send SCPI language commands to the instrument using input/output statements. On the other hand, IVI drivers use a hierarchical API, making it easy to write programs in modern, object oriented environments, using auto-complete capabilities in the source language to assist the programmer in writing the program.

Although IVI drivers are included as part of the LXI specification, any other type of driver is also acceptable. With the added leverage of Agilent Open, you can accelerate the integration of systems that include LXI devices and your existing test assets. Agilent Open is Agilent's combination of proven standards and time-saving tools for test automation. It includes software such as the Agilent I/O Libraries Suite, which supports millions of instruments from hundreds of vendors, in customer-preferred software development environments and use not only LAN but USB, GPIB, and other communications standards. Agilent Open instruments also provide built-in compatibility modes that facilitate migration from GPIB-based programming to LXI.

LXI system advantages

The LXI standard provides many advantages, including:

Cost

By adopting a common network interface from the computer, LXI leverages a high-volume, low-cost, long-lived standard communications medium. Today a Gigabit LAN switch costs less than thirty dollars, and allows four or more instruments to be added to the test system using cabling that costs dollars per meter (versus hundreds of dollars per meter for specialized cables for GPIB or PXI). There is no card cage or special controller to buy, and no empty card slots occupying space without function. Hybrid systems, as shown in Figure 4, composed of instruments of many interface types, can be configured to allow each technology (GPIB, PXI, VXI, and LXI) to perform where it does the best job. Adding LXI components to an existing system can be very inexpensive, because the underlying LAN is a high volume, low cost technology.



Figure 4. Hybrid test systems can be composed of classic GPIB instruments, card-cage instruments, and LXI instruments, all connected to the computer via LAN.

Space

LXI instruments do not require as much space as a full bench-top instrument, and some LXI instruments are as small as a 1U, half-rack size (41 x 213 mm) module, as shown in Figure 5. This may reduce instrument rack space by two to four times, allowing more instrument functionality in a small space, without requiring the purchase of a specialized card cage, controller, or cable. Many LXI instruments offer full bench instrument performance in less than half the space. Over time, the test system can migrate from classic instruments to their smaller LXI equivalents.

Distributed test capability

Because instruments are small and connected using LAN, they can be distributed around a laboratory, throughout a building, or around the world. The IEEE 1588 protocol allows these distributed systems to maintain precise timing despite their physical dispersion. Larger industries such as power generation, heavy manufacturing, and process control can automate larger tasks at lower cost than was possible with previous generations of instruments. LXI measurement instruments can be placed physically close to the transducers they measure, reducing wiring complexity and improving measurement integrity.

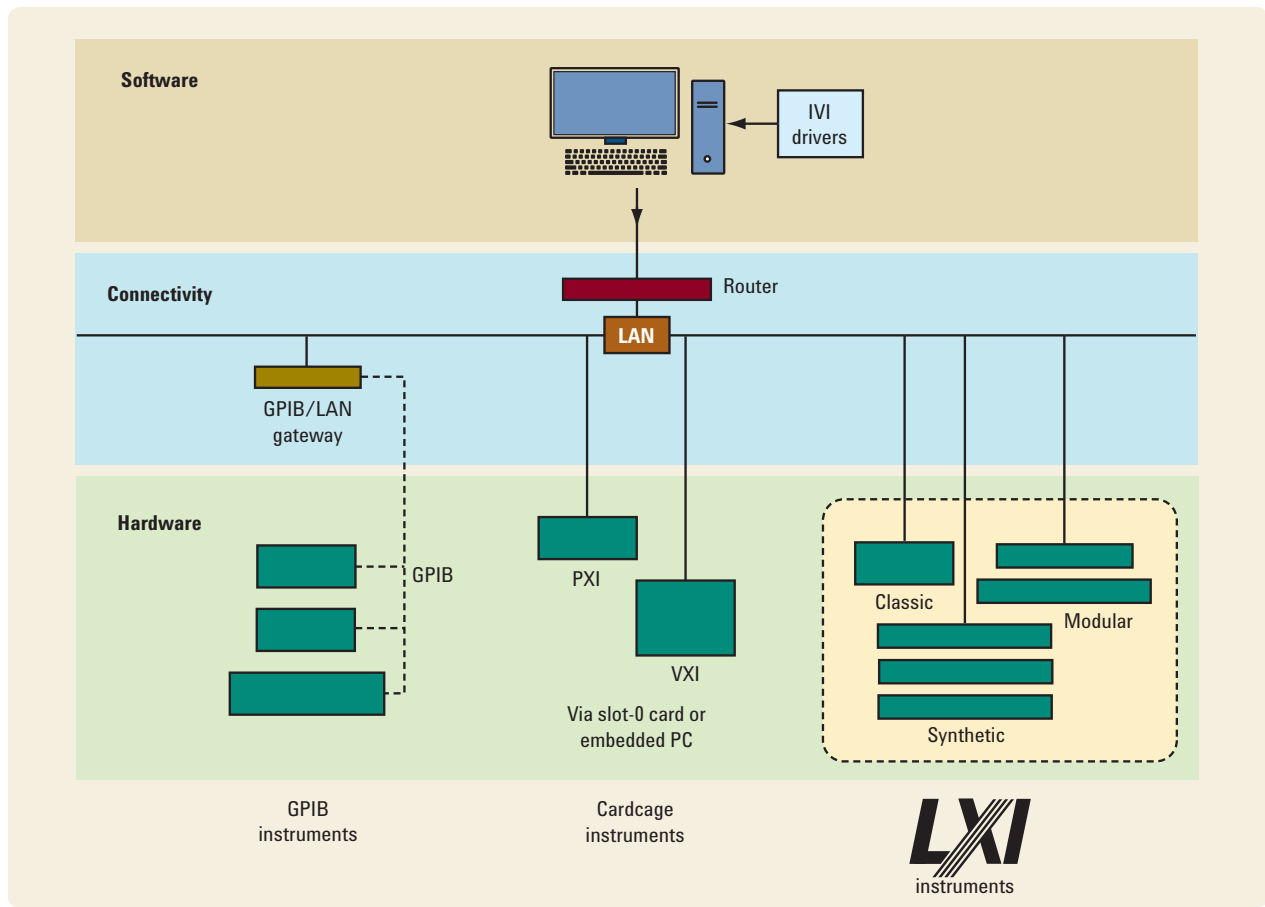

Figure 5. A classic-style digital multimeter (which includes LXI capability) shown above a smaller modular-style LXI switching instrument.

Speed

The LXI standard allows instruments to take advantage of faster computers and faster LAN speeds as the industry evolves. In just a few years, LAN speeds have increased one thousand-fold, and even faster LANs are continuing to emerge. LXI allows the electronic test industry to leverage this massive investment in computer and LAN technology, riding the waves of speed increases as they come.

Conclusion

LXI standard instruments, built by many electronic instrument manufacturers, allow instrument test systems to capitalize on the cost effective and widespread use of standard PC LAN interfaces. LXI enables fast, efficient, and cost-effective creation — and reconfiguration — of test systems, opening new possibilities in testing.

Additional information is available at <http://www.agilent.com/find/open>. To see Agilent's full LXI products and solutions, please visit <http://www.agilent.com/find/lxi>.

How to Set Up an LXI System

Some guidelines for setting up a networked test system

Grant Drenkow

Nanotechnology Program Manager, Agilent Technologies
grant_drenkow@agilent.com

LAN eXtensions for Instruments (LXI), introduced in September 2005, brings new flexibility to test systems. This flexibility provides lots of choices in terms of setting up a test system. Should you use a hub, a switch, or router in the system? Should the test system be isolated or connected to the corporate network? How do you get access to the test system from a remote computer?

GPIB has been the primary architecture in the test industry for over 30 years. In a GPIB system up to 14 devices are daisy-chained together and attached to a GPIB interface card installed in the computer (Figure 1). Each device on the bus has a specific address, allowing the computer to send commands to specific instruments. Each instrument responds to the command and returns data to the computer. An LXI system can be set up in a similar fashion or using the power of LAN, it can be configured in many other ways.

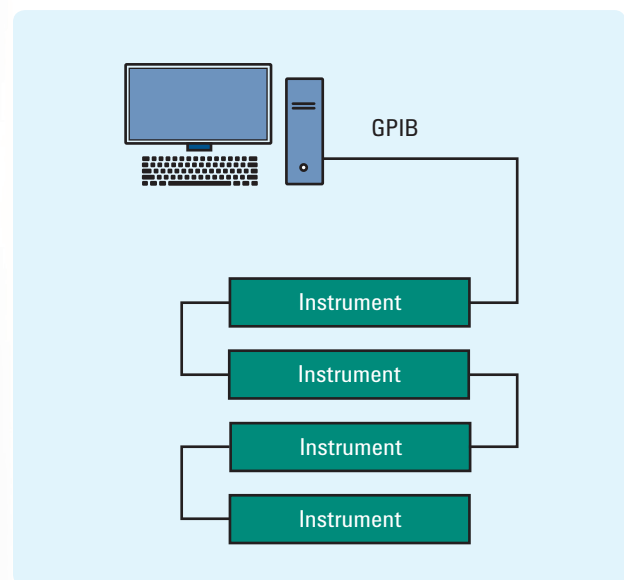

Figure 1. GPIB system

In LXI, the instruments and the computer are connected to a hub, switch, or router (Figure 2). The computer can communicate with individual instruments or with combinations of instruments. Instruments can also communicate with each other. The flexibility does not stop here. In an Ethernet system you can have multiple hubs, routers, switches, and computers. The big question — what is the best configuration for an LXI test system?

Hubs, switches, and routers are Ethernet devices that connect multiple computers and instruments.

Hub —The hub acts as a repeater taking in a message at one port and sending a copy of that message to all other ports.

Switch — The switch reads a message coming in from one port and sends that message to the appropriate port based on the destination address in the message. The switch only knows about its local network.

Router — The router connects multiple networks together. Like the switch it sends messages to the appropriate port based on the destination address in the message. The router can be used to isolate a local network from a larger corporate or public network.

Figure 2. Definition of hubs, switches, and routers.

Getting started with a private network

To get started, you need a computer with an Ethernet interface, a router or switch, and a couple of LAN cables. A private network is the easiest to set up. All the instruments and the computer are connected to the switch or router via LAN cables in a private network (Figure 3). This private network is not disturbed by the thousands of messages found on the corporate intranet or the billions of messages on the Web. Since the instruments and the computer are not connected to a public network they are not affected by the various bugs and viruses that infect networked computers.

In a LAN network, each device runs at its full speed, independent of the other instruments. For example, you can have a 10-Mbit, 100-Mbit, and a 1-Gbit instrument on a network and each will run at its top speed as long as the switch or router is as fast, or faster, than the highest speed instrument. Since computer technology changes faster than instruments, the computer will operate even faster on the network insuring that no bottlenecks occur.

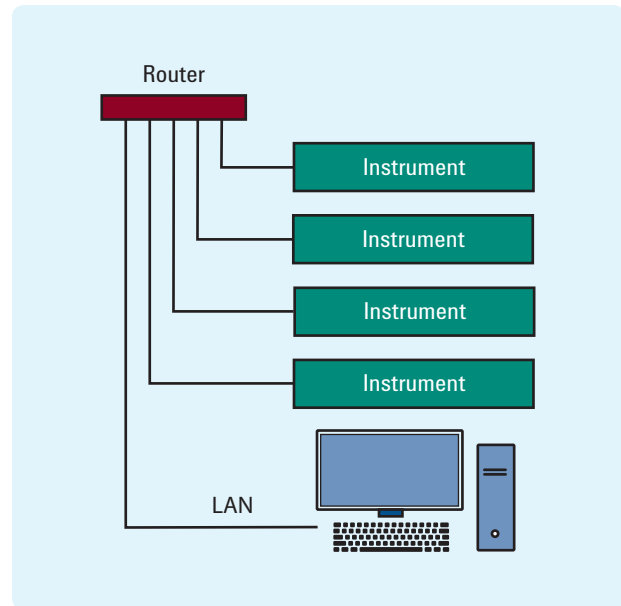

Figure 3. LXI private network

Connecting to the internal network

You can also connect LXI instruments directly to your corporate intranet since everything is Ethernet compatible (Figure 4). Once connected to the intranet, many users in the company have access to the instrument. The challenge is to work with your organization's information technology department (IT) to allow only authorized personnel to use them. The most common method is to place the instruments on a server protected by a password. Instruments connected inside the corporate firewall are protected fairly well from external users and harmful viruses.

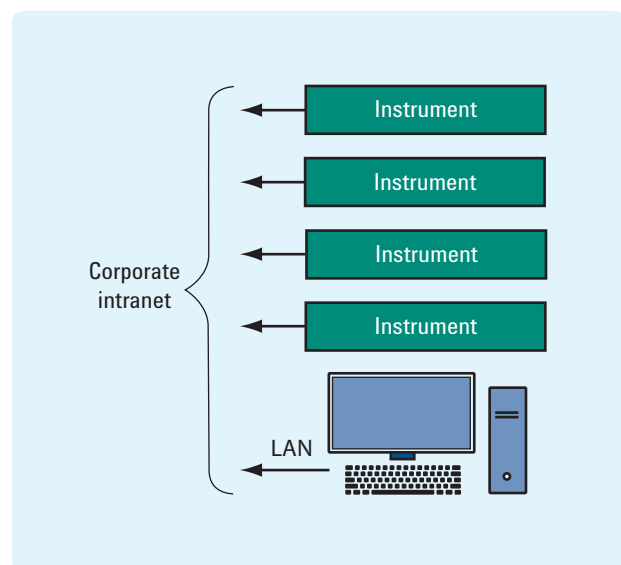

Figure 4. Direct connection to the internal network.

The challenge with using LXI devices on the corporate network is throughput performance. Depending on corporate intranet traffic, messages passing to and from the instruments can be delayed. Time-critical and mission-critical test systems should not connect directly to the corporate network. They need a private, dedicated network that will not be affected by the volume of message traffic that varies widely.

Creating your own subnet

It is possible to configure an LXI test system that runs independently at full speed and can be accessed from an external computer. Two configurations achieve this goal.

The first configuration entails connecting the router (and you must use a router here) from the private network (Figure 5) into the corporate network. Of course, the IT department will need to approve the router on the corporate network. In this configuration, the computer and the instruments run on their own private sub-network at full speed. The router isolates this sub-net from outside access. It assigns private IP addresses to the computer and the instruments. However, it is a one-way street — devices inside the private network can send information to the corporate network (or beyond) but no one outside the private network can see or communicate to devices in the private network.

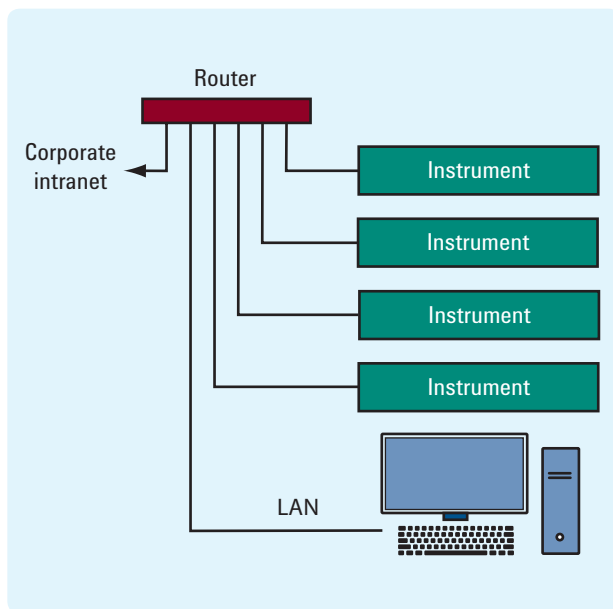

Figure 5. Connecting through a router from the private network.

The second configuration (Figure 6) is the preferred setup for a test system. In this configuration, you install a second LAN interface (network interface card) in the computer. One LAN interface connects to the test system switch (a router is not required) while the other interface connects to the corporate intranet. The computer operates the instruments at full speed on its private sub-net.

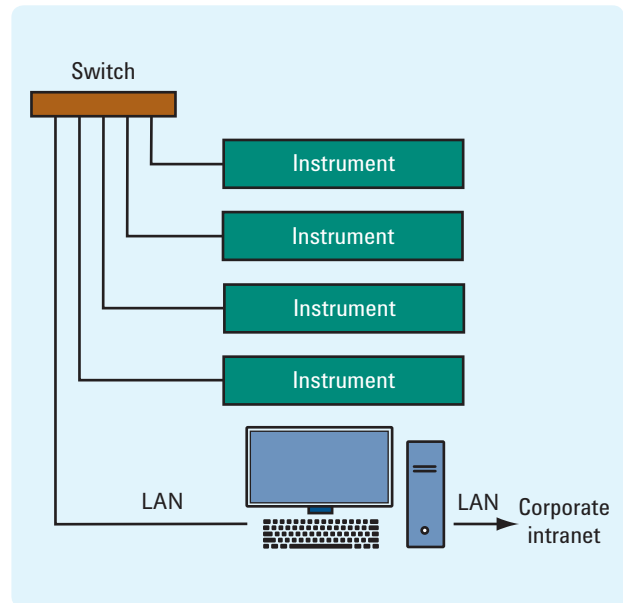

Figure 6. Connecting through a PC.

In this configuration, only the PC has access to the corporate network; the instruments run on their own private network without IT interference. It is possible to access the instruments from outside the private network by running the remote desktop application (found in Microsoft Windows® XP) on the computer in the private network. The “outside” computer takes control of the “inside” computer, sending commands to instruments or accessing data from them.

Adding precision timing to LXI

Class A and B LXI instruments use IEEE 1588 precision time protocol for accurate synchronization and timing. The instruments can synchronize their clocks through an off-the-shelf router but for precise timing you would be better off using a boundary clock — a special switch with built-in IEEE 1588 protocol. Instruments using IEEE 1588 timing should be placed on their own sub-net connected to the boundary clock. Other LXI instruments and the boundary clock itself would be connected to the main router, as shown in Figure 7.

Conclusion

LXI brings new flexibility to the world of test systems. And the good news — setting up the system is not difficult. It is very important to create a private network, isolated from corporate intranets and the World Wide Web. This insures the system is not affected by large volumes of message traffic and will operate the tests at full speed. Using a second network interface in the PC allows remote users to access this isolated system, without affecting system performance. Finally, you can continue to add more sub-nets to the test system, including an IEEE 1588 sub-net for accurate timing. Following these guidelines will insure a flexible and high-speed test system network.

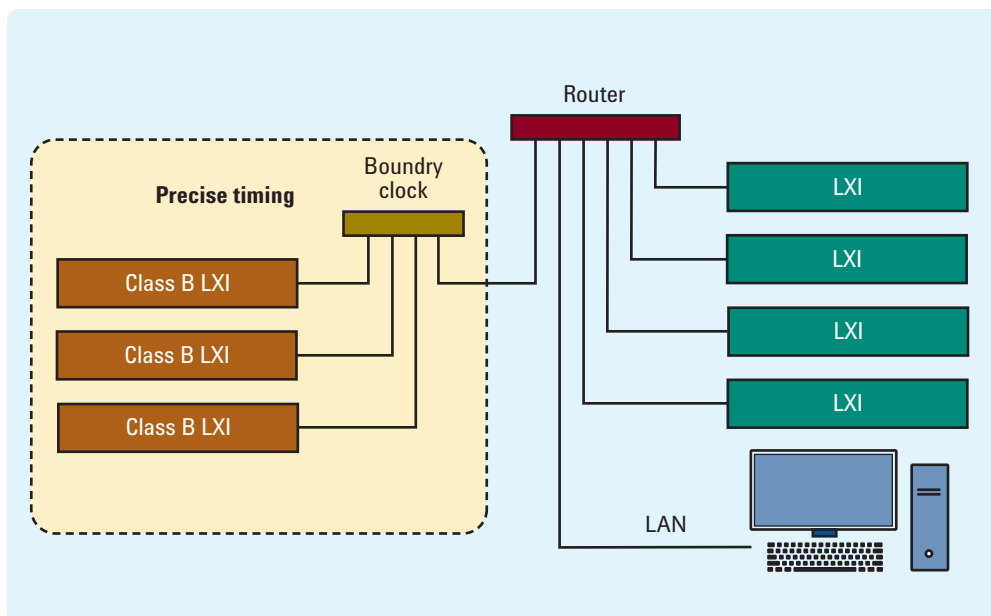

Figure 7. IEEE 1588 sub-net

Using Precision Time Protocol with LXI

How it works
and how you can benefit
from this technology

Stefan Kopp

Sales Development Expert, Agilent Technologies
stefan_kopp@agilent.com

The IEEE 1588 standard known as Precision Time Protocol, or PTP, is one of the more intriguing features of LXI. Unnoticed in the test and measurement industry before the advent of LXI, PTP introduces a fundamentally new approach to an important aspect of test: synchronization of system components. PTP's capabilities could change the way we address many common test requirements in the future.

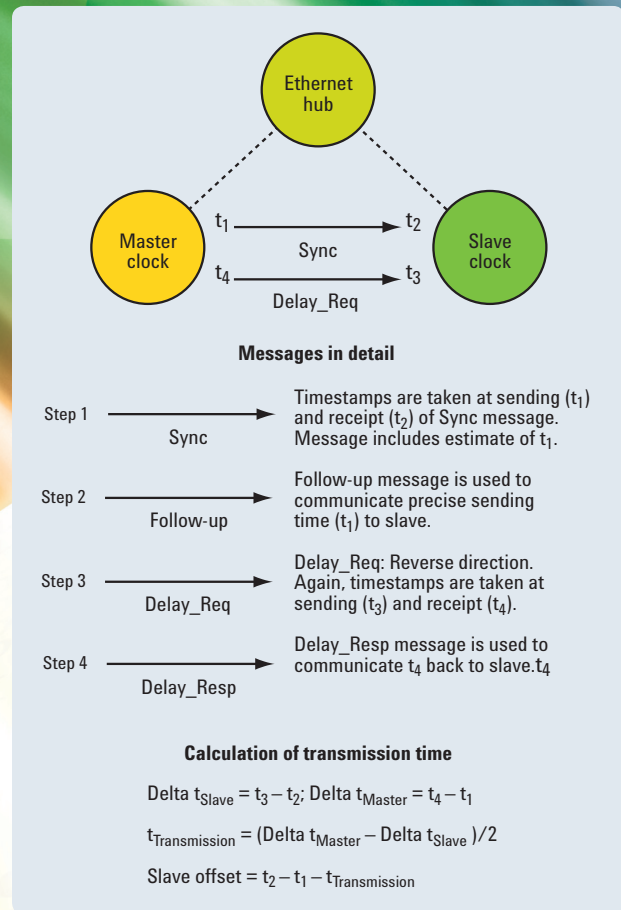

Figure 1. PTP messages and clock adjustment.

PTP accurately synchronizes the real time clocks that are built into many modern system components. Like the Network Time Protocol (NTP), PTP works across Ethernet and TCP/IP. However, PTP is orders of magnitude more accurate: synchronization down to 100 ns or better is easily achievable. You might think that such systems will be fragile and hard to configure, but they are not. As we will see below, system configuration is easy and mostly automatic. But let's look at some IEEE 1588 basics first.

PTP is based on a master-slave architecture. The slave clocks are synchronized to the master's clock (usually the one with the most stable and accurate timebase). The key to PTP's accuracy is how it takes the message transit time over the LAN into account when the slave clock offset is evaluated (see Figure 1).

As shown, the master clock sends a Sync message to the slave at regular intervals. The slave responds with a Delay_Req message. Both the sending and receiving of these messages are time-stamped by the clocks. The resulting four time stamps are then used to calculate the transmission time (the time the message is actually traveling on the physical network layer). Note that the calculation shown in Figure 1 is based on the idea that the transmission time is symmetric (with Ethernet, this is a perfectly reasonable assumption). With the Sync message time stamps and the transmission time, calculating the slave's clock offset becomes straightforward.

Hardware is better than software

Although it is not a mandatory requirement, for optimal performance, the time stamps are taken in hardware, on the physical network layer. Why is that so? The key to perfect synchronization is having stable and repeatable time stamps with low variance. This is best achieved with a hardware design (see conceptual block diagram in Figure 2).

With an Ethernet design that features a separate PHY chip (physical layer implementation), it is relatively easy to eavesdrop on the Ethernet frame's bit stream. The pattern matching hardware would then look for an outgoing Sync or incoming Delay_Req message pattern. Note that the IEEE 1588 specification clearly spells out at which bit transition time stamps are to be taken.

In the design described above, the time stamp is taken as the Ethernet frame is actually going out the door to the physical network layer. Consequently, the time stamp cannot be sent along as part of the same message. The Follow-Up message (see Figure 1) is used to communicate the time stamp (precise sending time) separately from the original Sync message.

In some situations, it might be sufficient and perfectly reasonable to use a software implementation for time stamping. However, the resulting synchronization accuracy will be at least an order of magnitude lower due to the timing fluctuation associated with the network protocol stack software.

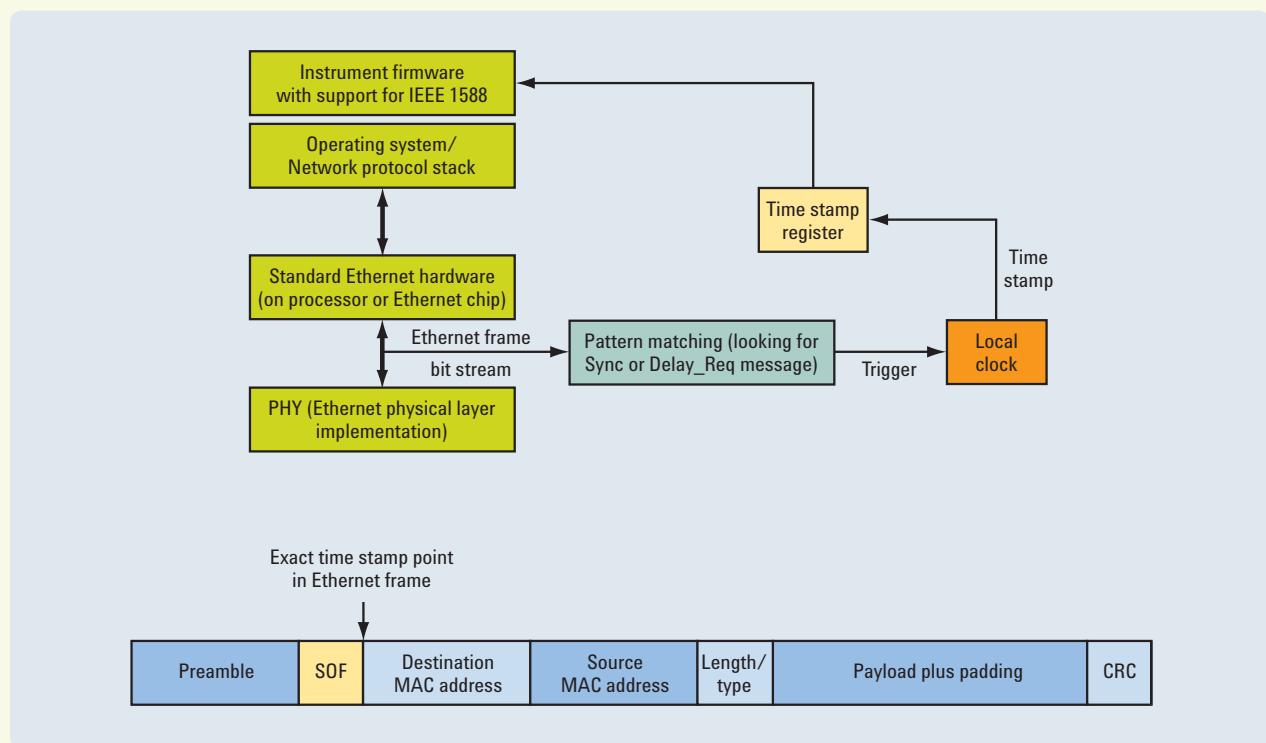

Figure 2. IEEE 1588 implementation in hardware (block diagram).

Network delay fluctuation is your enemy

As mentioned above, the clock correction algorithm is based on the assumption of symmetric transmission times. Consequently, fluctuations in the (one-way) transmission times will lead to a degradation of synchronization accuracy. For best performance, chose a network infrastructure with minimal delay fluctuation.

An Ethernet hub will show relatively low and stable delay by design. A hub is a simple signal repeater and the Ethernet frames are not stored or interpreted in any way. An Ethernet switch will show bigger delays and, more important, much higher delay fluctuation. The switch parses incoming frames and queues them for output on the proper destination port. A router introduces an even higher level of delay fluctuation because it inspects packets on the IP layer and stores and forwards them using software mechanisms.

If you want to use a switch or a router for their additional capabilities on network layer two or three, respectively, do you need to live with the increased delay fluctuation and the resulting decrease in synchronization accuracy? No, you don't. PTP uses a mechanism termed boundary clock to neutralize the negative effect of network elements that introduce high delay fluctuation (see Figure 3).

A boundary clock is a switch or router that has its own built-in real time clock and is aware of IEEE 1588. Except for PTP timing messages like Sync and Delay_Req, it behaves like a normal switch or router. However, with regards to PTP, the boundary clock terminates the "synchronization path" behind each individual port. The port which is connected to the best clock (grandmaster clock) will assume the role of a slave clock. Consequently, the internal clock in the switch or router will be synchronized to the grandmaster clock through this port. All other ports will assume the role of a master clock. As a result, all slave clocks in their respective synchronization path will synchronize to the boundary clock's internal clock.

The boundary clock mechanism drastically increases the synchronization accuracy (to the level of a simple Ethernet hub) because the IEEE 1588 timing messages are not switched or routed through the network element (unlike all other Ethernet frames or IP packets). Consequently, a major source of delay fluctuation (storage and processing in the network element) is taken out of the equation.

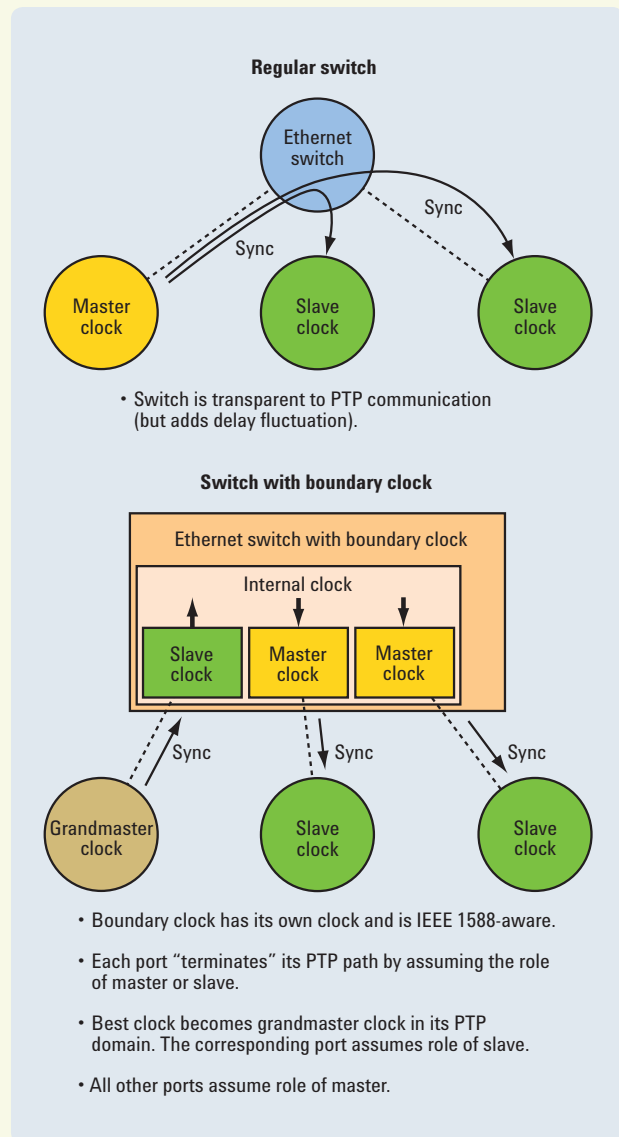

Figure 3. Boundary clock

How far can you push the limit?

As we have seen, a system designed for maximum performance would need to follow two important rules. First, it would use a hardware-assisted implementation of IEEE 1588 in the master and slave clocks. Second, it would use an appropriate network infrastructure: either a simple Ethernet hub or a more complex network element (switch or router) with a boundary clock. If you follow these rules, how far can you push the limit in terms of synchronization accuracy?

With hardware-assisted techniques, the accuracy is limited by two elements: the clock recovery of the PHY implementation and the stability of the local clock/oscillator itself. Expect the clock recovery fluctuation to be in the low single digit nanosecond range for a fast Ethernet implementation. The effect of this jitter can be reduced quite effectively through statistical methods. The drift of the local oscillator largely depends on the system design and could easily dwarf the clock recovery issues. Note that the Sync message interval can be reduced to 1s, but not less. A high stability design would need to show limited drift that matches the stability of the clock recovery (low nanosecond range). This might require a relatively costly solution based on an oven-controlled oscillator.

The best designs will include appropriate statistical methods to reduce the effect of delay fluctuation. The IEEE 1588 standard does not specify an averaging algorithm to be used, so this is another area where manufacturers can make a unique contribution in their solutions.

Easy to set up

One of the best aspects of IEEE 1588 is that the system configuration is mostly automatic (unless you chose to steer the configuration process). How is that possible? Each and every clock maintains a number of data sets which describe its inherent capabilities (such as its stability) and its actual configuration (such as an estimate of the current time offset to the master, as well as the identification of the master clock). These (and other) parameters together describe the quality of a clock and they are “published” as part of every Sync message sent out by the clock.

When a clock comes online, it will assume the role of master and start to send Sync messages (containing its specification). Other clocks will receive the quality parameters and compare them to their own specification (by way of the best master clock algorithm). If they see that a better master clock is out there, they will assume the role of a slave.

What are the criteria for a good clock? One important parameter is the clock stratum. This value indicates if the clock is directly or indirectly traceable to a common standard source of time, such as through a GPS receiver. Clocks that feature a direct link to such an absolute source of time are preferred. Another important parameter is the “clock variance,” an indication of the clock’s inherent stability.

As mentioned earlier, you can alter the default or automatic configuration if desired. For this purpose, the IEEE 1588 standard also defines a number of management messages. These allow you to query the clock’s data sets, set the current time, and change the clock status or other operating parameters via the LAN.

What you can do with this technology

Data acquisition is one obvious application for IEEE 1588. Many data acquisition applications require sensors to be distributed over a large area (such as in wireless or wireline communication or industrial facilities). But even in centralized applications, different instruments or data acquisition units need to be synchronized. In all but the most trivial applications, it is very important to know when the individual measurements were done. The high timing accuracy provided by IEEE 1588 leads to more possibilities in post-processing and analysis, which in turn leads to better insight. Without IEEE 1588, you would need to synchronize instruments through independent GPS receivers or use a centrally-generated trigger signal for synchronization. The first option is expensive, and the latter is not trivial due to the effect of propagation delay and trigger jitter through noise.

Functional test is another area that will benefit greatly from IEEE 1588. Often, stimuli need to be applied in a predefined sequence and with exact timing. Likewise, the DUT’s reaction needs to be measured or recorded at a predefined point in time. Even complex scenarios are easy to implement using the time-based triggering enabled by IEEE 1588. Without IEEE 1588, you may need to generate one or several hardware trigger signals and route these to the various instruments in an appropriate way. Time-based triggering gives you much more flexibility because it is not limited by physical wiring and does not suffer from signal quality issues.

Conclusion

If you are working on system applications, take notice; IEEE 1588 is a fascinating technology. This technology and the features it enables could make your life easier. PTP enables system-wide time-stamping and precise time-based triggering without the need for sophisticated wiring. It thereby introduces an unprecedented level of flexibility in this area.

Measuring Oscilloscope Sampling Fidelity

Digital storage oscilloscopes (DSOs) with the highest sample rates do not always produce the most accurate measurements — sampling fidelity is just as important

Johnnie Hancock

Applications Engineer, Agilent Technologies
johnnie_hancock@agilent.com

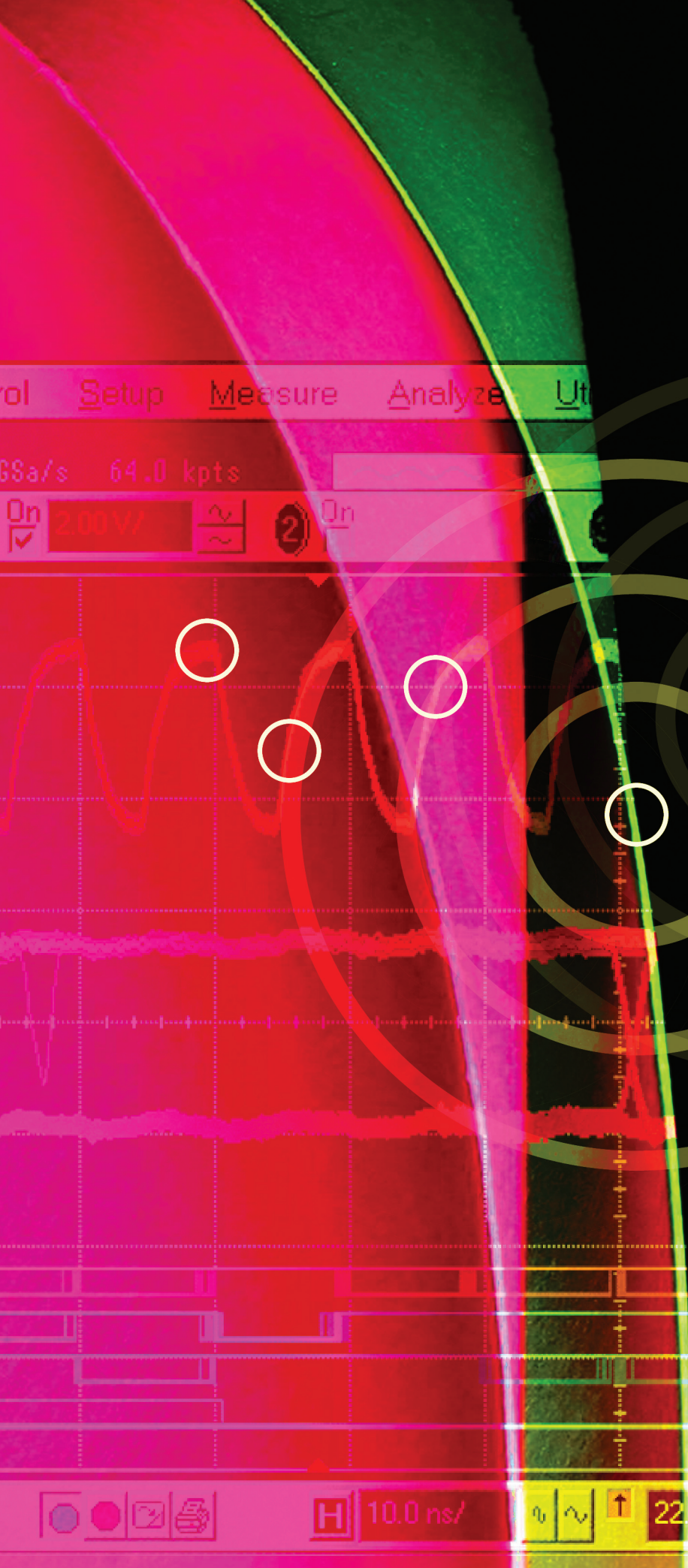

DSOs are the primary tools used today by digital designers to perform signal integrity measurements such as setup/hold times, eye margins, and rise/fall times. Engineers often assume that scopes with the highest sample rates produce the most accurate digital measurements — but this is not always true. The two key specifications that affect an oscilloscope’s signal integrity measurement accuracy are bandwidth and sample rate; you probably know how much bandwidth you need, but do you understand how a scope’s sampling fidelity can distort your measurements? Using side-by-side measurements on oscilloscopes with various bandwidths and sample rates, this article will demonstrate a counter intuitive concept: scopes with higher sample rates can exhibit poorer signal fidelity because of poorly aligned interleaved analog-to-digital converters (ADCs).

The minimum required sample rate for accurate oscilloscope measurements is based on Nyquist’s sampling theorem which can be summarized into these two important rules:

1. The first rule is that the highest frequency component sampled, f_{MAX} , must be less than half the sampling frequency, f_s .
2. The second rule, which is often forgotten, is that samples must be equally spaced.

A minimum sample rate-to-bandwidth ratio of 4:1 is required for scopes with a Gaussian frequency response, in order to always eliminate the possibility of sampling frequency components above the -3 dB bandwidth frequency (f_{BW}). Oscilloscopes with bandwidth specifications of 1 GHz and below typically exhibit this type of response. A minimum sample rate-to-bandwidth ratio of 2.5:1 is sufficient for scopes with a maximally-flat response, which is typical of scopes with bandwidths greater than 1 GHz. However, even when an oscilloscope has met these minimum sample rate requirements based on Nyquist’s first rule, increasing sample rates can sometimes result in a violation of Nyquist’s 2nd rule — equally-spaced samples.

Interleaved real-time sampling

When ADC technology has been stretched to its limit in terms of maximum sample rate, how do oscilloscope vendors create scopes with even higher sample rates? It is not as easy as simply selecting an off-the-shelf ADC with a higher sample rate. A common technique adopted by all major scope vendors is to interleave multiple real-time ADCs. But do not confuse this sampling technique with interleaving samples from repetitive acquisitions, which we call equivalent-time sampling.

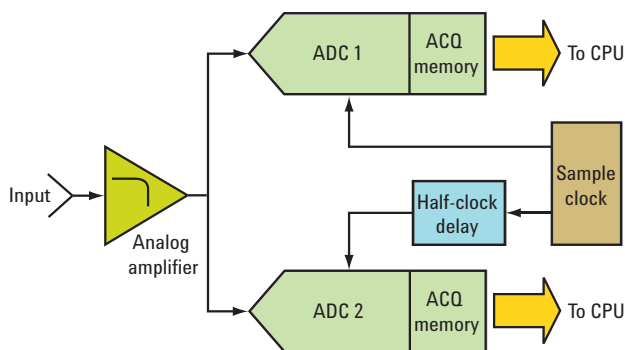

Figure 1. Real-time sampling system consisting of two interleaved ADCs.

Figure 1 shows a block diagram of a real-time interleaved ADC system consisting of two ADCs with phase-delayed sampling. In this example, ADC 2 always samples a half-clock period after ADC 1 samples. After each real-time acquisition cycle is complete, the scope’s CPU retrieves the data stored in each ADC acquisition memory and then interleaves the samples to produce the real-time digitized waveform with twice the sample density (two times sample rate).

Scopes with real-time interleaved sampling must adhere to two requirements. For accurate distortion-free interleaving, each ADC’s vertical gain, offset, and frequency response must be closely matched. Secondly, the phase-delayed clocks must be aligned with high precision in order to satisfy Nyquist’s second rule that dictates equally-spaced samples — the sample clock for ADC 2 must be precisely 180 degrees out of phase with the clock that samples ADC 1. Both of these criteria are important for accurate interleaving.

The timing diagram shown in Figure 2 illustrates incorrect timing of interleaved samples where the phase-delayed clock system of two interleaved ADCs is not exactly 180 degrees out of phase. This diagram shows where real-time digitized points (red dots) are actually converted relative to the input signal. But due to the poor alignment of the phase-delayed clocking (green waveforms), these digitized points are not evenly spaced.

When the scope's CPU retrieves the stored data from each ADC's acquisition memory, it assumes that samples from each memory device are equally spaced. In an attempt to reconstruct the shape of the original input signal, the scope's $\text{Sin}(x)/x$ reconstruction filter produces a severely distorted representation of the signal, as shown in Figure 3.

Because the phase relationship between the input signal and the scope's sample clock is random, real-time sampling distortion, which is sometimes referred to as sampling noise, may be interpreted mistakenly as random noise when you are viewing repetitive acquisitions. But it is not random at all; it is deterministic and directly related to the harmonics of the scope's sample clock.

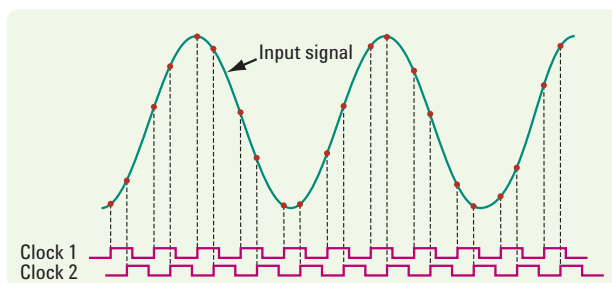

Figure 2. Timing diagram showing non-evenly spaced samples.

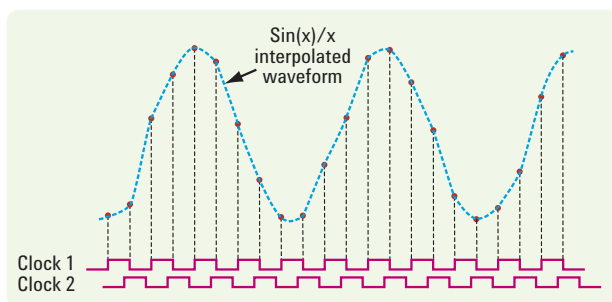

Figure 3. Timing diagram showing distorted reconstruction of waveform using $\text{Sin}(x)/x$ filter due to poor phase-delayed clocking.

Testing for interleave distortion

Unfortunately, oscilloscope vendors do not usually provide specifications in their DSO data sheets that directly quantify the quality of their scope's digitizing process. However, there are a variety of tests that you can easily perform to not only measure the effect of sampling distortion, but also to identify and quantify sampling distortion. Here is a list of tests you can perform on scopes to detect and compare interleave distortion:

1. Effective number of bits (ENOB) analysis using sine waves
2. Visual sine wave comparison tests
3. Digital clock measurement stability comparison tests
4. Spectrum analysis comparison tests

ENOB analysis using sine waves

The closest specification that some scope vendors provide to quantify sampling fidelity is effective number of bits (ENOB). But ENOB is a composite specification consisting of several error components including input amplifier harmonic distortion and random noise. Although an ENOB test can provide a good benchmark comparison of overall accuracy between scopes, ENOB is not a very well understood concept, and it requires exporting digitized data to a PC for analysis.

Basically, an ENOB test first extracts a theoretical best-fit sinusoidal signal from the digitized sine wave. This sine wave curve-fit algorithm will eliminate any errors induced by oscilloscope amplifier gain and offset inaccuracies. The test then computes the RMS error of the digitized sine wave relative to the ideal/extracted sine wave over one period. This RMS error is then compared to the theoretical RMS error that an ideal ADC of N bits would produce. For example, if a scope's acquisition system has 5.3 effective bits of accuracy, then it generates the same amount of RMS error that a perfect 5.3-bit ADC system would generate.

A more intuitive and easier test to conduct, to see if a scope produces ADC interleave distortion, is to simply input a sine wave from a high-quality signal generator with a frequency that approaches the bandwidth of the scope. Then make a visual judgment about the purity of the shape of the digitized and filtered waveform.

Another easy test you can perform is to compare parametric measurement stability, such as the standard deviation of rise times, fall times, or V_{p-p} , between scopes of similar bandwidth. If interleave distortion exists, it will produce unstable measurements — just like random noise.

ADC distortion due to misalignment can also be measured in the frequency domain using a scope's FFT math function. With a pure sine wave input, the ideal/non-distorted spectrum should consist of a single frequency component at the input frequency. Any other spurs in the frequency spectrum are components of distortion. You can also use this technique on digital clock signals, but the spectrum is a bit more complex.

Visual sine wave comparison tests

Figures 4a and 4b show the simplest and most intuitive comparative test — the visual sine wave test. The waveform shown in Figure 4a is a single-shot capture of a 1-GHz sine wave using an Agilent Infiniium MSO8104A 1-GHz bandwidth scope, sampling at 4 GSa/s. This scope has a sample-rate-to-bandwidth ratio of 4:1 using non-interleaved ADC technology. The waveform shown in Figure 4b is a single-shot capture of the same 1-GHz sine wave using a competitor's 1-GHz bandwidth scope, sampling at 20 GSa/s. This scope has a maximum sample-rate-to-bandwidth ratio of 20:1 using interleaved technology.

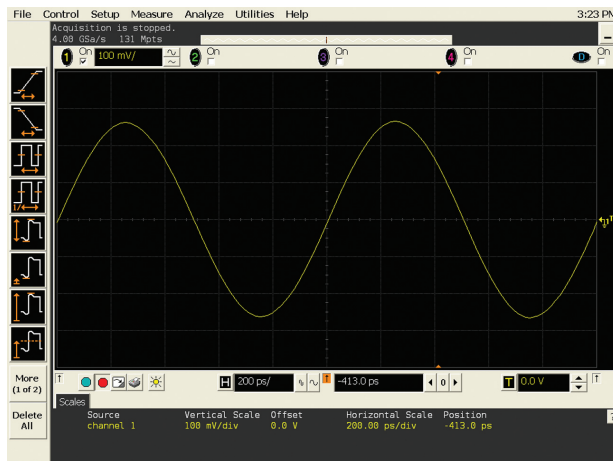

Figure 4a. 1-GHz sine wave captured on an Agilent MSO8104A 1-GHz bandwidth oscilloscope sampling at 4 GSa/s.

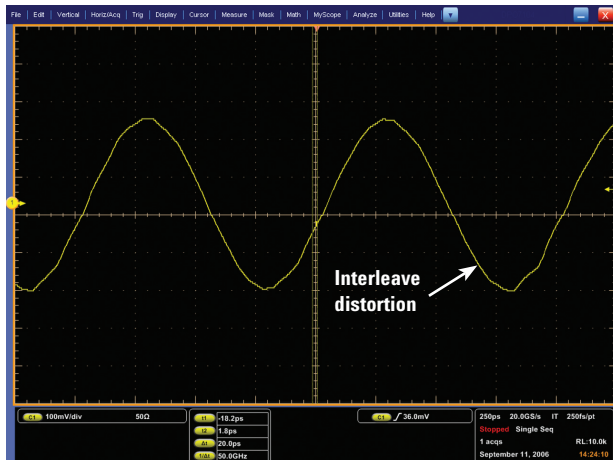

Figure 4b. 1-GHz sine wave captured on a competitor's 1-GHz bandwidth oscilloscope sampling at 20 GSa/s.

Although we would intuitively believe that a higher-sample-rate scope of the same bandwidth should produce measurement results that are more accurate; we can see in this measurement comparison that the lower sample rate scope actually produces a much more accurate representation of the 1-GHz input sine wave. This is not because lower sample rates are better, but because poorly aligned interleaved real-time ADCs negate the benefit of higher sample rates.

Precision alignment of interleaved ADC technology becomes even more critical in higher-bandwidth and higher-sample-rate scopes. Although a fixed amount of phase-delayed clock error may be insignificant at lower sample rates, this same fixed amount of timing error becomes significant at higher sample rates (lower sample periods). In the next section of this article, we will compare two higher-bandwidth scopes that use real-time interleave technology to achieve up to 40 GSa/s real-time sampling.

Digital clock measurement stability comparison tests

As a digital designer, you may say that you really do not care about distortion on analog signals, such as on sine waves. But you must remember that all digital signals can be decomposed into an infinite number of sine waves. If the fifth harmonic of a digital clock is distorted, then the composite digital waveform will also be distorted.

Although it is more difficult to perform sampling distortion testing on digital clock signals, it can be done. But making visual distortion tests on digital signals is not recommended, because there is no such thing as a pure digital clock generator. Digital signals, even those generated by the highest-performance pulse generators, can have varying degrees of overshoot and perturbations, and can have various edge speeds. In addition, pulse shapes of digitized signals can be distorted by the scope's front-end hardware, due to the scope's pulse response characteristics and possibly a non-flat frequency response.

But there are a few tests you can perform using high-speed clock signals to compare the quality of a scope's ADC system. One test is to compare parametric measurement stability, such as the standard deviation of rise times and fall times. Interleave sampling distortion will contribute to unstable edge measurements and inject a deterministic component of jitter into the high-speed edges of digital signals.

Figure 5 shows two scopes with similar bandwidth, capturing and measuring the rise time of a 400-MHz digital clock signal with edge speeds in the range of 250 ps. Figure 5a shows an Agilent 3-GHz bandwidth scope interleaving two 20-GSa/s ADCs to sample this signal at 40 GSa/s. The resultant repetitive rise time measurement has a standard deviation of 3.3 ps. Figure 5b shows a competitor's 2.5-GHz bandwidth scope interleaving four 10-GSa/s ADCs to also sample at 40 GSa/s. In addition to a more unstable display, the rise time measurement on this digital clock has a standard deviation of 9.3 ps. The more tightly aligned ADC interleaving in the Agilent scope, along with a lower noise floor, makes it possible for the Agilent scope to more accurately capture the higher-frequency harmonics of this clock signal, thereby providing measurements that are more stable.

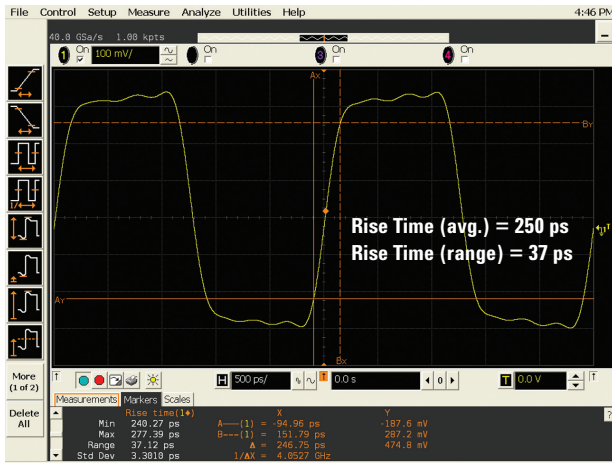

Figure 5a. 400-MHz clock captured on an Agilent Infiniium DS080304B 3-GHz oscilloscope sampling at 40 GSa/s.

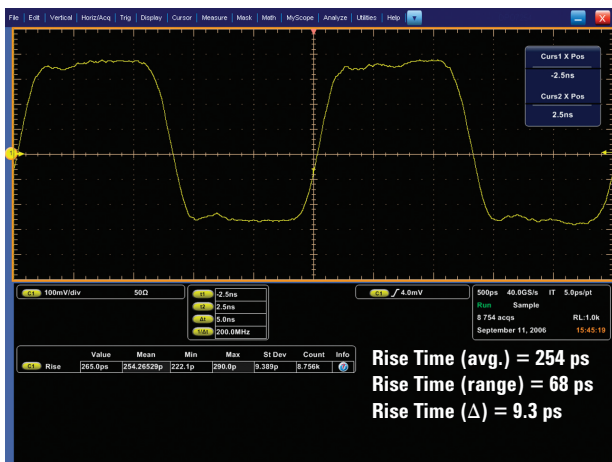

Figure 5b. 400-MHz clock captured on a competitor's 2.5-GHz oscilloscope sampling at 40 GSa/s.

Spectrum analysis comparison tests

The visual sine wave test and measurement stability test do not really identify where the distortion is coming from; they merely show the effect of various error components of distortion. However, a spectrum/FFT analysis will positively identify components of distortion, including harmonic distortion, random noise, and interleaved sampling distortion. Using a sine wave generated from a high-quality signal generator, there should be only one frequency component in the input signal. Any frequency components other than the fundamental frequency detected in an FFT analysis on the digitized waveform are the result of distortion.

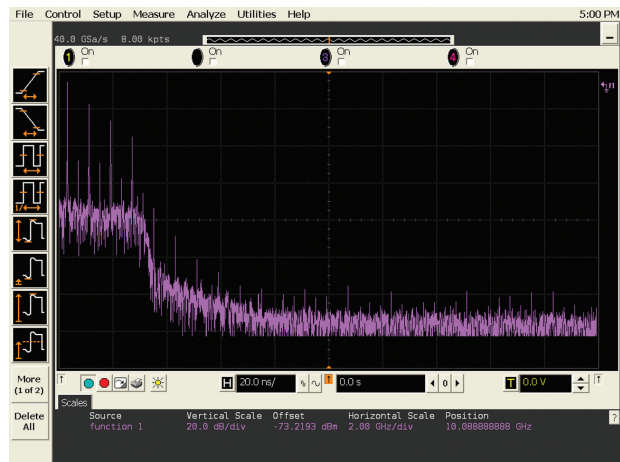

Figure 6a. FFT analysis on 400-MHz clock using an Agilent Infiniium DS080304B 3-GHz bandwidth oscilloscope.

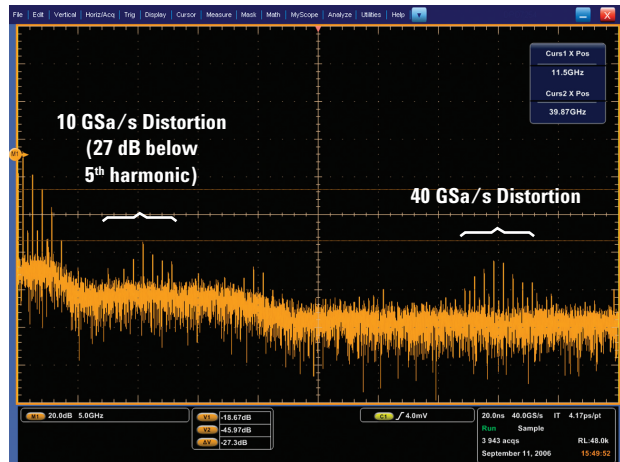

Figure 6b. FFT analysis on 400-MHz clock using a competitor's 2.5-GHz bandwidth oscilloscope.

When you view the frequency components of a digital clock signal using FFT analysis, the spectrum is much more complex than when you test a simple sine wave. A pure digital clock generated from a high-quality pulse generator should consist of the fundamental frequency component and its odd harmonics. If the duty cycle of the clock is not exactly 50 percent, then the spectrum will also contain even harmonics of a lower-amplitude. But if you know what to look for and what to ignore, you can measure interleave sampling distortion on digital signals in the frequency domain using the scope's FFT math function.

Figure 6a shows the spectrum of a 400-MHz clock captured on an Agilent 3-GHz bandwidth scope sampling at 40 GSa/s. The only observable frequency spurs are the fundamental, third harmonic, fifth harmonic, and seventh harmonic, along with some minor even harmonics. All other spurs in the spectrum are well below the scope's in-band noise floor.

Figure 6b shows the spectrum of a 400-MHz clock captured on a competitor's 2.5-GHz bandwidth scope, also sampling at 40 GSa/s. In this FFT analysis, we not only see the fundamental frequency component and its associated harmonics, but we also see several spurs at higher frequencies clustered around 10 GHz and 40 GHz. These imaging spurs are directly related to this scope's poorly aligned interleaved ADC system

Conclusion

There is more to oscilloscope signal fidelity than just sample rate. In some cases a lower-sample-rate scope may produce more accurate measurement results.

To satisfy Nyquist criteria, you need a scope that samples at least 2.5 to 4 times higher than the scope's bandwidth specification, depending on the scope's frequency roll-off characteristics. Achieving higher sample rates often requires that scope vendors interleave multiple real-time ADCs. But if real-time interleaving is employed, it is critical that the interleaved ADCs be vertically matched, and the timing of phase-delayed clocking must be precise. The problem is not the number of interleaved ADCs; the issue is the level of precision of interleaving. Otherwise, Nyquist's second rule (equally-spaced samples) can be violated, thereby producing distortion and often negating the expected benefit of higher sample rates.

For more information about oscilloscope sample rates and sampling fidelity, download Agilent's application note 1587, *Evaluating Oscilloscope Sample Rates vs. Sampling Fidelity: How to Make the Most Accurate Digital Measurements*, publication number 5989-5732EN.

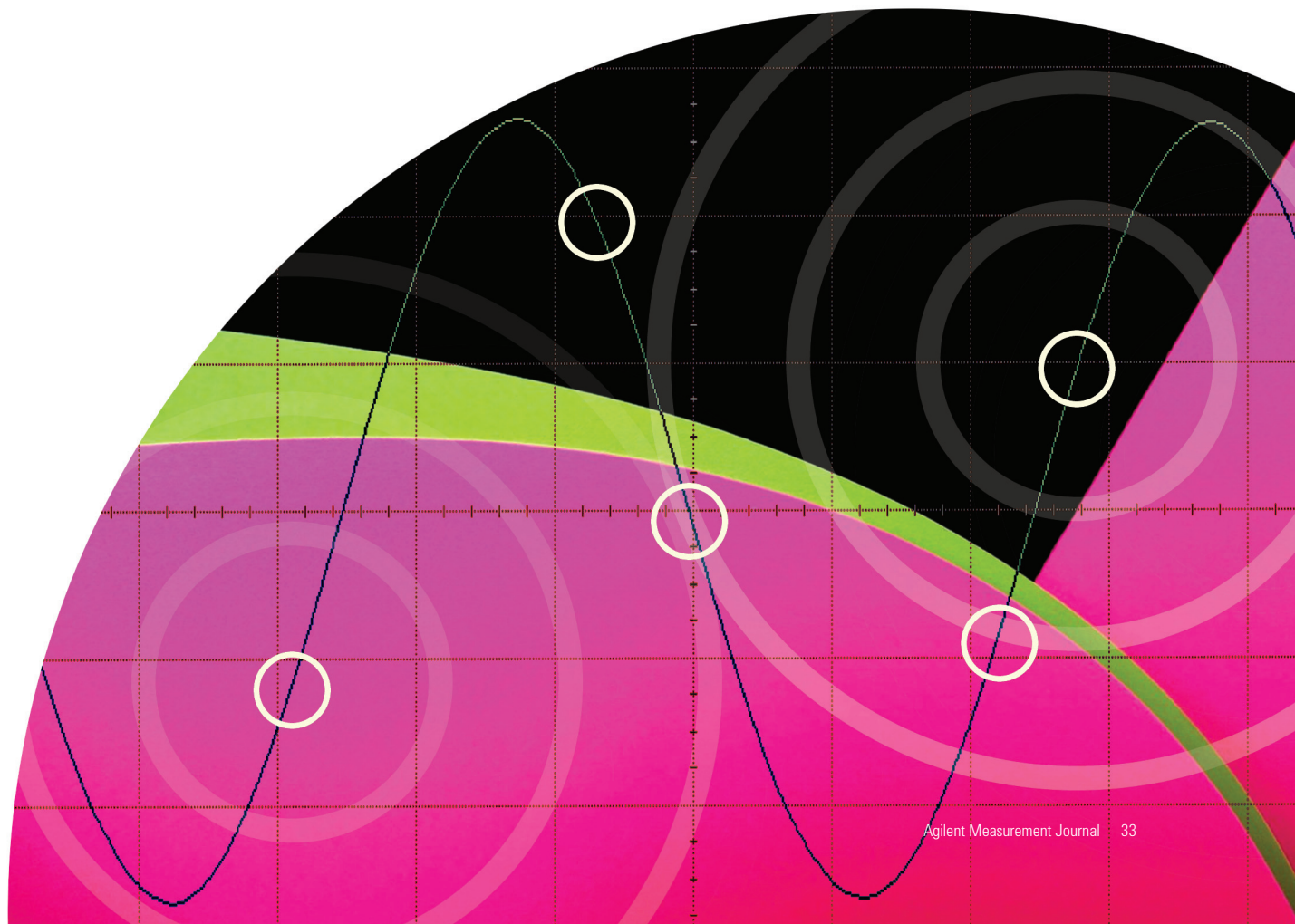



Analog-to-Digital Converters

20 years of progress in
Agilent oscilloscopes

John Corcoran

Department Manager, Agilent Laboratories
john_corcoran@agilent.com

Ken Poulton

Project Manager, Agilent Laboratories
ken_poulton@agilent.com

Over the past 20 years, the real-time (transient capture) bandwidth of Agilent Technologies' oscilloscopes has increased by more than 40 times, from 250 MHz in 1987 to 13 GHz today. An enabling factor in achieving this increase in bandwidth is the sample rate of the internal analog-to-digital converter (ADC) which digitizes the oscilloscope input signal for storage in digital memory.

Correspondingly, Agilent's scope ADC sample rates have grown from one gigasample/second (1 GS/s) in 1987 to 40 GS/s today. In this article we will review how scope ADC architectures have been optimized over the past two decades to best exploit the available integrated circuit (IC) technology and enable this performance increase. To do this, we will describe three benchmark ADC designs, one from 1987, one from 1997, and the ADC in use in Agilent's high-end oscilloscopes today.

How does a 40:1 increase in ADC sample rate correspond to the progress due to Moore's Law over the past two decades? Moore's Law, of course, describes the amazing increases in MOS integrated circuit density and performance due to scaling — the result of shrinking transistor sizes. We can perhaps use personal computer (PC) clock rate as a measure of the progress due to Moore's Law. If you bought a new PC in 1987, you were performing your word processing on a microprocessor with about a 25 MHz clock rate. In 1997, you could buy a PC with close to 250 MHz clock rate. Today, PCs are available with clock rates of 2.5 GHz or higher. So, roughly speaking, progress under Moore's Law has delivered a factor of 100 in PC clock rate over the past 20 years.

However, this progress in MOS IC technology is not solely responsible for the progress in ADC sample rates. In 1987, it was not possible to build a 1 GS/s ADC with MOS IC technology. The fastest IC technologies available at that time were based on GaAs FET and silicon bipolar transistors. Although neither of these were a good choice for building a microprocessor, they were the right choice if you wanted to build the world's fastest scope ADC. In 1997, silicon bipolar technology had evolved to higher speeds and obviated the need for GaAs FETs, allowing a more compact design. By the turn of the century, however, CMOS technology had caught up with bipolar technology in throughput, if not in raw speed, and offered intriguing possibilities for very high speed ADCs. But as we will describe later, exploiting CMOS for ADCs required substantial ADC architecture and system design changes.

Types of oscilloscopes

There are two types of oscilloscopes in common use today, usually called sampling oscilloscopes and real-time oscilloscopes. To understand the motivation for building very high sample rate ADCs for scopes, it is important to understand the difference.

Sampling oscilloscopes

Sampling scopes are typically very high bandwidth (up to 80 GHz today). But to get that high bandwidth, they use samplers that operate at low sample rates, typically under 1 MHz. Sampling scopes work only with repetitive signals, and those signals are typically sequentially digitized. First, a clock synchronized with the input signal triggers the oscilloscope to capture a sample. After that sample is digitized the trigger input is re-armed. When the next clock occurs, a small delay is introduced before taking another sample. With each successive clock signal, larger delays are introduced. In that way, the signal is sequentially "traced out" by the scope (see the sine wave example of Figure 1).

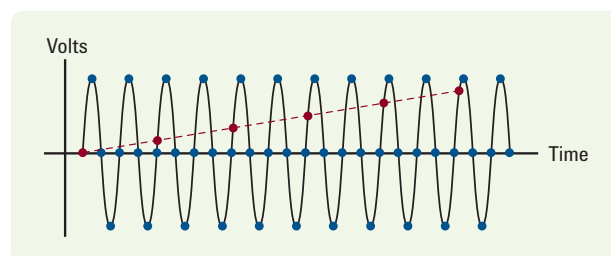

Figure 1. Sampling scopes (red dots) acquire a single cycle of the signal only after multiple repetitions. Real-time scopes (blue dots) acquire the same signal in a single occurrence.

Sampling scopes are often used for characterizing the quality of high-speed communication signals by displaying eye diagrams. In these signals bandwidth is often very high and the signal is repetitive, so sampling scopes are a very good match.

Real-time oscilloscopes

Real-time scopes capture a complete image of the input signal in a single occurrence — they can even capture one-time events. To do this, the sample rate of the ADC must be more than twice the bandwidth of the signal being captured. Most scopes use ratios between 2.5 and 4 to allow for implementation of practical reconstruction filters for best waveform fidelity.

Real-time scopes are most commonly used in debugging digital systems, where infrequent glitches can occur — sometimes crashing the system. These glitches would be missed by a sampling scope, but are completely captured by a real-time scope if it has adequate bandwidth. Likewise, serial communication signals in use in PCs today (such as Serial ATA and PCI Express) may occasionally have bit errors. A real-time scope can capture the complete signature of such an error and accelerate system debugging. Digital systems today have multi-GHz clock rates, and modern serial communication systems operate at 2.5 Gb/s, 5 Gb/s, or even 10 Gb/s. These applications demand very high bandwidth real-time scopes, and therefore, very high sample rate ADCs.

Real-time scopes — historical overview

Since 1980, Agilent Technologies, Inc.* has introduced digitizing oscilloscopes using nine custom-designed analog-to-digital converters ICs. A number of these converters were designed at Agilent Labs, others at Agilent business units¹. For the purpose of this article we will focus on the design choices of just three ADCs (from 1987, 1997, and today) that highlight the evolution of IC technology and ADC architectural changes over the past 20 years.

In 1987, Agilent introduced the world's first oscilloscope with a 1-GS/s ADC, the 54111D (see Figure 2). The key enabling technology was a GaAs FET sampler chip that drove four silicon bipolar digitizers. Ten years later, in 1997, silicon bipolar technology had increased in f_T (transistor cutoff frequency) by a factor of five. Along with architectural changes, this enabled an 8-GS/s ADC

system using only bipolar technology. A family of scopes was introduced that used this ADC, including the Agilent 54845A (as shown in Figure 3) which had 1.5 GHz bandwidth. Most recently, 0.18-micron CMOS technology was exploited to enable a 40-GS/s scope channel. Memory was built into the ADC chip for capturing the digitized data. Agilent's fastest real-time scope is the DSO81304B (as shown in Figure 4) which samples at 40 GS/s with 13 GHz bandwidth.

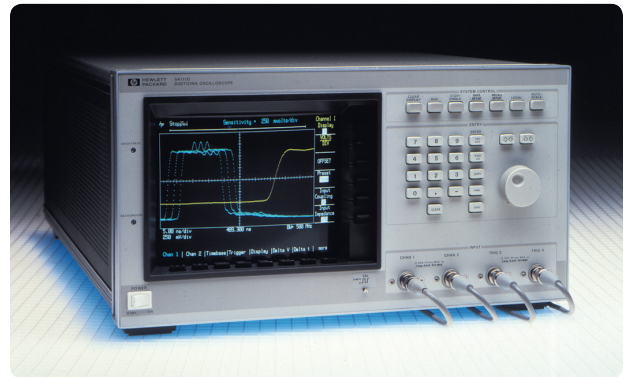

Figure 2. 54111D 1-GS/s digitizing oscilloscope



Figure 3. 54845A 8-GS/s Infiniium oscilloscope

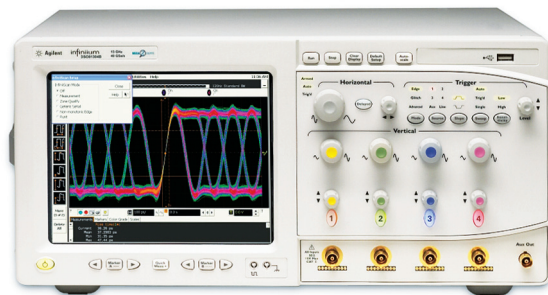

Figure 4. DSO81304B 40 GS/s Infiniium oscilloscope

*All technologies and products mentioned in this article prior to 2000 were developed and sold under the Hewlett-Packard name.

It is interesting to compare the performance of these ADCs and scope channels across various measures (see Table 1). From 1987 to today, sample rate increased by 40 times, bandwidth by 52 times, resolution by 2 bits (or 4 times), and memory depth by 250 times. Power, interestingly, stayed about the same at 20 W per ADC channel, with memory included. But power efficiency, measured in watts per gigasample, dropped from 20 to 0.5, for a 40 times improvement. Given the nominal 2 extra bits of resolution, the figure of merit of power/gigasample per conversion step has improved by 160 times.

Table 1. Progress in ADC performance since 1987.

	1987	1997	Today	Today vs 1987
Sample rate	1 GS/s	8 GS/s	40 GS/s	40x
Real-time bandwidth	250 MHz	1.5 GHz	13 GHz	52x
Resolution	6 bits	8 bits	8 bits	4x
Memory depth	8 kB	64 kB	2 MB	250x
Power	20 W	27 W	20 W	1x
Watts/gigasample/s	20	3.4	0.5	40x
Chip count	10	4	2	5x

1987: The world's first 1-GS/s 6-bit ADC

Bipolar IC technology was the logical choice for ADCs in the 1980s due to its excellent device matching and relatively high device speeds ($5 \text{ GHz } f_T$). This technology was capable of building a 400-MS/s 6-bit ADC on one chip using a modification of the flash ADC architecture, with about 100 MHz of input bandwidth². However it was clear that the marketplace required sample rates of 1 GS/s, and analog bandwidths as high as 1 GHz for use with repetitive signals.

The solution for the sample rate shortfall was to time-interleave multiple ADC ICs. Four such chips, each operating at 250 MS/s (a 4 ns period), but clocked sequentially 1 ns apart, would supply an aggregate sample rate of 1 GS/s. To improve the bandwidth, a sample and hold circuit would precede each digitizer (ADC) as shown in Figure 5. GaAs FET technology was chosen for this role, due to its 14-GHz transistor f_T and high-speed Schottky diodes, which are well suited to sample and hold applications. All four samplers would be integrated on one GaAs chip.

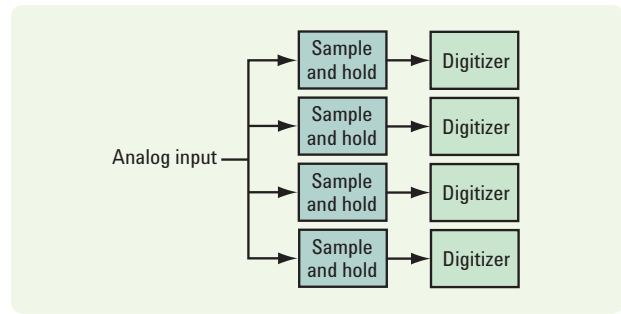

Figure 5. Four 250 MS/s sample and hold circuits and ADCs are time-interleaved to produce a 1 GS/s system.

However, a significant problem remained. When using time-interleaved samplers to capture a fast input signal, errors are introduced if the sampler clocks are not precisely timed (see Figure 6). To achieve 6-bit accuracy at a 1 GHz input frequency, the clocks would have to be timed to an accuracy of 2 ps, and this was judged to be impractical. The solution was to add a 1-GS/s first rank sample and hold circuit to the GaAs chip (see Figure 7). This sampler distributed settled samples to the four second rank samplers in turn. Because the second rank inputs were not moving when sampled, precise timing of their clocks was no longer required.

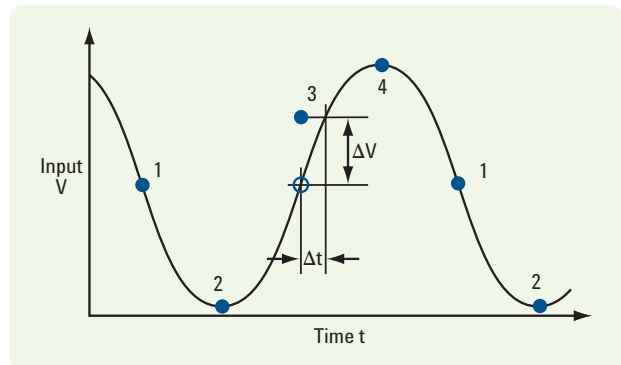

Figure 6. A small sample and hold timing error can produce a significant error in the sampled voltage.

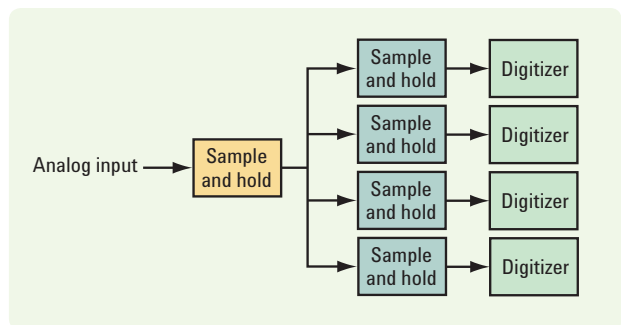

Figure 7. A two-rank sample and hold system, with the first sampler operating at 1 GS/s, can eliminate sensitivity to interleave timing errors.

A complete block diagram for the 1-GS/s ADC system is shown in Figure 8. A second GaAs chip was used to supply the clocks for the system. In addition, a custom 16 kB CMOS memory chip was designed to accept data from the converters. All chips except the memory were integrated on a custom thick film hybrid, shown in Figure 9. This system combined the strengths of three very different kinds of IC processes: GaAs for highest speed, bipolar for highest accuracy and CMOS for highest density of memory integration.

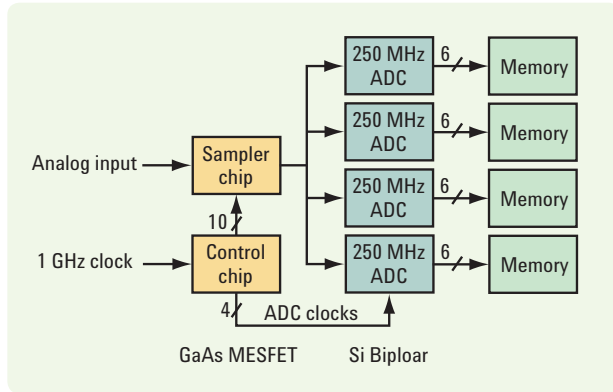

Figure 8. Complete block diagram of 1 GS/s ADC system.

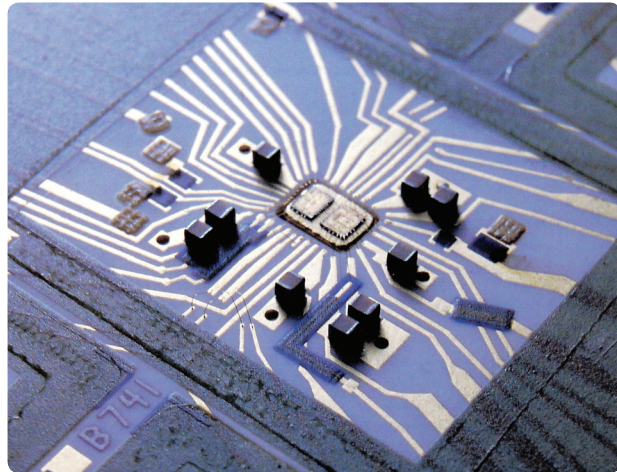

Figure 9. Thick film hybrid package for 1 GS/s ADC system.

Performance of the ADC system exceeded expectations. Analog bandwidth was 1.7 GHz, and 5.2 effective bits were achieved at 1-GHz input frequency and 1 GS/s³. The 54111D oscilloscope included numerous other significant technical achievements⁴, and the product received strong acceptance in the marketplace.

1997: An 8-GS/s bipolar ADC system

The manufacturing cost of electronics does not change very much with the number of transistors in a chip, but is strongly related to the number of chips and the type of technology used in those chips. In the early 1990s, Agilent developed a world-leading 25-GHz- f_T silicon bipolar process. Although it was an all-bipolar process, it was designed to take advantage of advances in CMOS lithography equipment to make many transistors with high yields. The high yield of the process offered the possibility of making a major step in complexity on a given chip, while reducing the chip count. The speed of the process offered the possibility of increasing the bandwidth and accuracy of the system while eliminating the more expensive GaAs chips.

The block diagram of this 8-GS/s system is shown in Figure 10. This system interleaves four bipolar digitizer blocks as in the 1-GS/s system; the sample rate of each one was increased by a factor of eight due to the faster process and circuit improvements. The resolution of each digitizer was increased from six bits to seven bits using an architectural feature known as interpolation; a combination of dither and a special digital filter increased the resolution at low input frequencies to eight bits. The higher process yield allowed higher complexity levels: increased resolution, on-chip preamp, digital with decimation logic, and putting two digitizers on a single chip. This reduced the chips in an acquisition channel from ten to four.

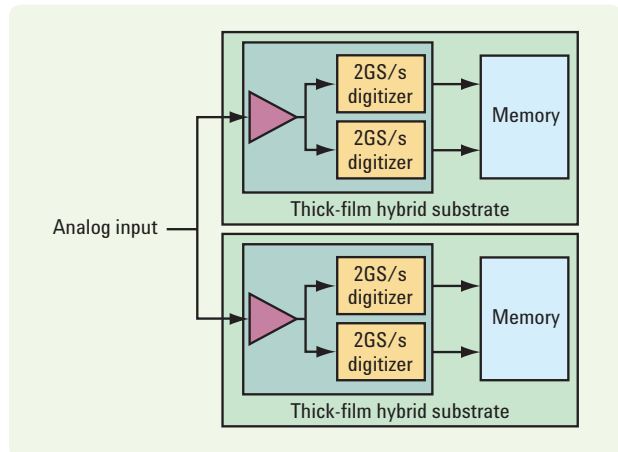

Figure 10. Block diagram of the 4-chip 8-GS/s ADC system.

This block diagram, however, has no single first-rank sampler, so it could suffer from time-interleaving errors at high input frequencies. The timing requirement is also eight times more stringent due to the higher input frequencies — up to at least 2 GHz. The solution came in the form of two inventions: programmable delay elements for the clock paths with picosecond resolution and stability, and algorithms to allow programmatic calibration of the delay elements.

The result is seen in Figure 11, showing the accuracy in effective bits versus input signal frequency. At low frequencies the DC accuracy of the ADC system is 6.7 bits. At higher input frequencies, the accuracy was reduced by distortion and jitter, but still provided the world's highest-accuracy ADC system for input signals above 1 GHz⁵.

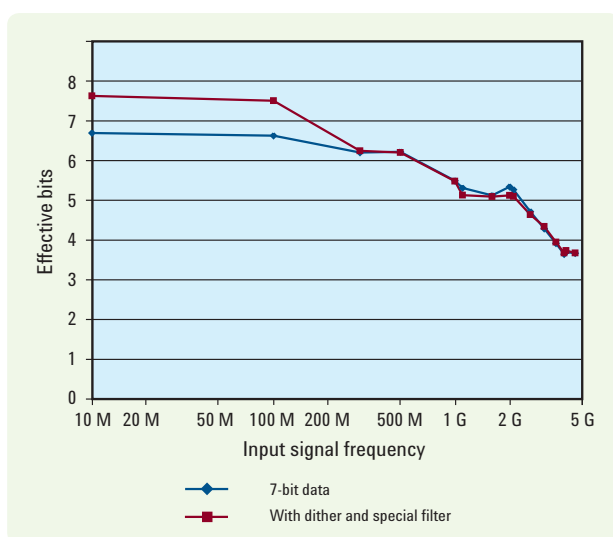

Figure 11. Accuracy of the 8 GS/s ADC.

Today: The world's fastest ADC chip — in CMOS

In the late 1990s, CMOS processes were improving steadily, following Moore's Law, while bipolar process developments were improving less rapidly. We asked ourselves whether we could take advantage of the steady progress of CMOS.

At first, it seemed like a silly question. Existing 8-bit CMOS ADCs were 60 times slower than bipolar ADCs, and CMOS transistors are intrinsically about ten times less accurate than bipolar transistors. We came up with a radical departure from previous architectures to take advantage of the strengths of CMOS:

- Rather than building the fastest unit digitizer possible, we aimed at the most power-efficient unit digitizer. For 8-bit ADCs, CMOS pipelines are many times more power efficient (in gigasample/second/watt) than bipolar ADCs.
- We decided to run the pipelines at their most power-efficient speed and time-interleave as many pipelines as necessary to reach the required overall sample rate. This utilizes the biggest strength of CMOS: lots of transistors.
- We gave each pipeline converter its own input sampler connected directly to the analog input. The fastest clock signal used is only 1 GHz.
- To create the many very accurate sampling clocks required, we invented a clock generator using a delay-locked loop, dividers, and two levels of digitally-controlled delay circuits.
- For the pipeline digitizers, we chose an open-loop, current-mode circuit topology. Open loop circuits are generally faster than the more common feedback circuits, and current mirrors are more linear than the usual voltage amplifiers in CMOS.
- We made all the circuits as small as possible to reduce power, and relied on extensive calibration to make the overall conversion accurate. This uses even more transistors.

Our first CMOS ADC⁶, initially shipped in oscilloscopes in 2002, replaced the 1997 4-GS/s bipolar ADC with a 4-GS/s, 8-bit CMOS ADC that used only one-third the power, and cost less than one-third as much, with better accuracy. This demonstrated the power of an architecture designed to fit the strengths of CMOS.

We then followed that with the world's fastest ADC in any technology: an 8-bit ADC at 20 GS/s⁷. To do this, we used a standard 0.18-micron CMOS process, built pipeline digitizers that ran at 250 MS/s, and time-interleaved an unprecedented 80 of these pipelines to reach 20 GS/s.

This ADC is used for input signals up to 13 GHz, which requires much higher bandwidth and much better timing accuracy than the bipolar converter operating on a 2-GHz signal. We addressed the bandwidth need by using carefully-optimized NMOS FET samplers. This is the only circuit in CMOS that can achieve 13 GHz bandwidth with the one percent linearity needed for scopes, so these samplers must be connected directly to the input pads. The resulting input capacitance (2 pF) is then driven from a small bipolar input buffer chip mounted in the same package as the CMOS ADC.

The last part of the puzzle is what to do with 20 GBytes/s of output data — about 100 times the write rate of a fast disk drive. We decided to take advantage of the integration capability of CMOS yet again and integrate the sample storage memory on the ADC chip. The resulting chip contains 50 million transistors; it is shown in Figure 12. The chip is dominated by the memory array in the bottom of the chip; the ADCs are in the upper portion. At the top is the separate input buffer chip.

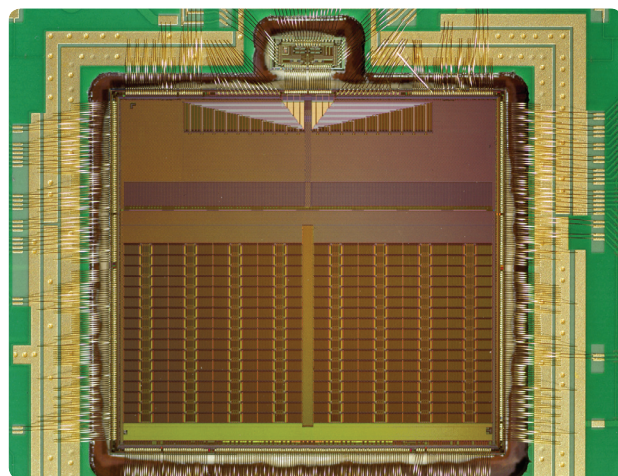

Figure 12. 20-GS/s CMOS ADC chip

Today's fastest Agilent oscilloscopes use one or two of these chips for each channel to reach sample rates up to 40 GS/s.

Conclusion

What will the next 20 years bring in scope performance? CMOS technology is still moving forward and certainly will offer improvements in the performance of digital circuits. But the analog characteristics of CMOS devices are getting worse with CMOS scaling. Breakdown voltages and transistor gains are decreasing, and leakage currents are increasing, much to the detriment of analog circuits. On the other hand, carbon nanotubes or other device and process technologies may mitigate some of these problems. Alternatively, new circuit design approaches further exploiting redundancy or digital error correction may allow analog circuits to function well enough even with low yield or poorly functioning devices.

Will we see another 40 times improvement in ADC sampling rate (to over 1 THz) in the next 20 years? It seems unlikely. In fact, it seems just about as unlikely as 40 GS/s ADCs must have seemed to us in 1987.

References

1. *A 4 GHz 8b Data Acquisition System*, Ken Rush and Patrick J. Byrne, ISSCC Digest of Technical Papers, pp. 176 to 177, Feb., 1991
2. *A 400 MHz 6b ADC*, John Corcoran and Knud Knudsen, ISSCC Digest of Technical Papers, pp. 294 to 295, Feb., 1984
3. *A 1 GHz 6-bit ADC System*, Ken Poulton, John Corcoran, and Tom Hornak, IEEE Journal of Solid-State Circuits, pp. 962 to 970, Dec., 1987
4. *A One-Gigasample-Per-Second Digitizing Oscilloscope — Hewlett-Packard's HP54111D*, Joe K. Millard, HP Journal, June 1988
5. *An 8-GSa/s 8-bit ADC System*, Ken Poulton, Knud L. Knudsen, John Kerley, James Kang, Jon Tani, Eldon Cornish and Michael VanGrouw, IEEE VLSI Symposium on Circuits, 1997
6. *A 4-GSample/s 8b ADC in 0.35-um CMOS*, Ken Poulton, Robert Neff, Art Muto, Wei Liu, Andy Burstein, Mehrdad Heshami, IEEE International Solid State Circuits Conference Digest of Technical Papers, pp. 166 to 167, Feb 2002
7. *A 20-GS/s 8b ADC with a 1-MByte Memory in 0.18-um CMOS*, Ken Poulton, Robert Neff, Brian Setterberg, Bernd Wuppermann, Tom Kopley, Robert Jewett, Jorge Pernillo, Charles Tan, Allen Montijo, IEEE International Solid State Circuits Conference Digest of Technical Papers, pp. 318 to 319, Feb 2003

Collaborating to Create a New Laboratory

Agilent Technologies joins Philips and Cascade Microtech to create a new Electronic Measurement Laboratory at High Tech Campus Eindhoven

Erica Depaula

*Market Development Manager — Europe, Middle East and Africa,
Agilent Technologies
erica_depaula@agilent.com*

Agilent Technologies Inc. recently announced a collaboration between the Microsystems Plaza (MiPlaza) shared research facility, Philips, and Cascade Microtech, to establish a world-class electronic measurement laboratory at MiPlaza on the High Tech Campus Eindhoven, Netherlands.

The laboratory will enable development of the increasingly complex and high speed chips which are at the heart of next generation wireless systems. Such innovations include wireless communication in the home, providing the infrastructure for ambient intelligence, high-frequency RF imaging systems in hospitals, and ultralow power wireless sensors for use in and around the human body.

These wireless innovations will demand massively increased data transfer rates, 100 to 1000 times higher than currently available. This means increased bandwidth and consequently higher frequencies. The new laboratory supports these requirements, enabling measurements to be performed at very high-frequency in the microwave range.

The laboratory will be equipped with state of the art high-frequency measurement instrumentation, including Cascade Microtech's

probes and probe station, and Agilent Technology's PNA Series network analyzer, parametric analyzer, and IC-CAP device modeling software, capable of handling 300-mm wafers and measuring up to 67 GHz. The laboratory will enable research groups to perform precise electrical measurements on semiconductor integrated circuits (ICs), directly on-wafer, and will be fully supported by specialist applications personnel and measurement consultancy.

MiPlaza is part of Philips Research, and is one of the largest shared research service centers in the world. It offers world-class infrastructure and expertise, enabling customers and partners to carry out high-tech research and development projects in the most cost-effective way. The laboratory will be available for research partnership programs, where corporate innovation leaders, start-up companies, and academic and research institutes can utilize this advanced measurement facility in an open innovation environment.

As well as establishing the new laboratory, MiPlaza, Agilent and Cascade will also pursue an applications development program, keeping the measurement platform up to date with world-class standards, and increasing the shared expertise on wafer-level characterization applications.

"We are very pleased with the collaborative work being done with MiPlaza", said Benoit Neel, vice president and general manager, Agilent Technologies — Europe, Middle East, and Africa. "It is Agilent's strategic intent to work with the leading research entities and industry champions to facilitate innovation. Agilent believes that initiatives such as MiPlaza create tremendous opportunities for technical advancement."

The establishment of this major new laboratory is another excellent example of open innovation in practice: the principle that fundamental technological breakthroughs and generic innovations can best be achieved through close cooperation between companies, research centers, and universities.

The collaboration gives further economic impetus to the region, already one of the most technologically innovative in Europe.

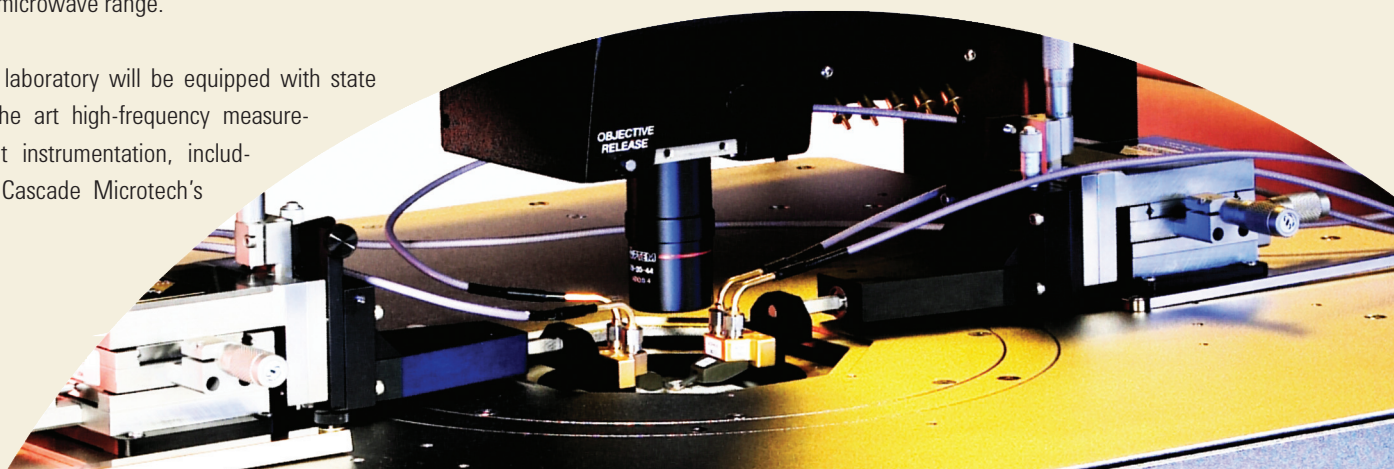

Innovations

Agilent MXG — Signal Generation Technology Reaches New Heights

Randy Becker

Product Marketing Engineer, Agilent Technologies
randy_becker@agilent.com

John Hansen

Senior Product Manager, Agilent Technologies
john_s_hansen@agilent.com

The Agilent MXG signal generator was introduced in September 2006 and its technical contributions have prompted significant interest and curiosity

The Agilent MXG has been a huge success, due in part to the technical breakthroughs that made it possible. How were these breakthroughs achieved? What were the enabling technologies and processes that enabled these breakthroughs? How can engineers learn from this product's implementation, not only to improve their knowledge but also to apply this knowledge to other applications and advance the state of the art?

This article offers some information that may help answer these questions. It includes some insights into the design attributes that enabled the industry-leading specifications and includes an overview of the high-level approach and team aspects that were critical to the project.



MXG overview

The new Agilent MXG signal generators have made significant technical contributions to the test and measurement industry, including:

- Fast switching — Switching time is usually less than 1 ms for signal frequency, amplitude and waveform.
- Signal Integrity — Adjacent Channel Power Ratio (ACPR) is over 70 dB and EVM is < 0.5 percent
- Cost of ownership — Instrument support logistics are dramatically improved with repair time less than 30 minutes and calibration time less than one hour.

A simplified block diagram of a general vector signal generator is shown in Figure 1. The Agilent MXG also has this same basic block diagram, and the specific implementation of these elements will be highlighted throughout this article.

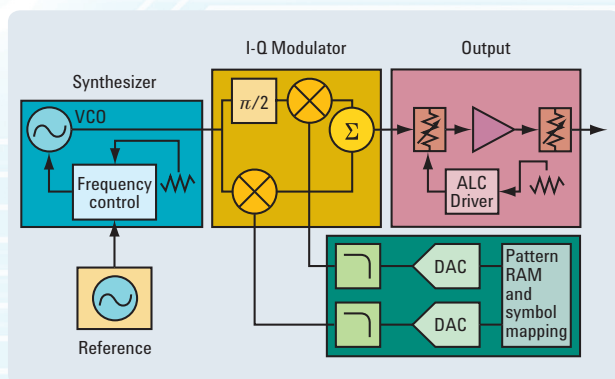

Figure 1. Simplified block diagram of the vector signal generator.

Switching speed

The switching speed of the Agilent MXG is typically less than 1 ms for changes in frequency, amplitude, or waveform. This is 10 to 50 times faster than the previous generation RF synthesizers, and

depends not only on fast building blocks, but also on a carefully coordinated system design. These switching times are enabled by:

- Frequency synthesizer design
 - VCO technology versus YIG
 - Wider PLL bandwidth and lower phase noise
- Faster command processing time, signal generator system design
 - Faster analog building blocks with digital control
 - High speed communication to each building block
 - Firmware optimization

Frequency synthesizer design

The frequency synthesizer inside the Agilent MXG generates the continuous wave (CW) RF signal. Each time the carrier frequency is changed, the synthesizer must move its output to the new frequency, representing a significant portion of the total switching time¹. A simplified block diagram of the synthesizer is shown in Figure 2.

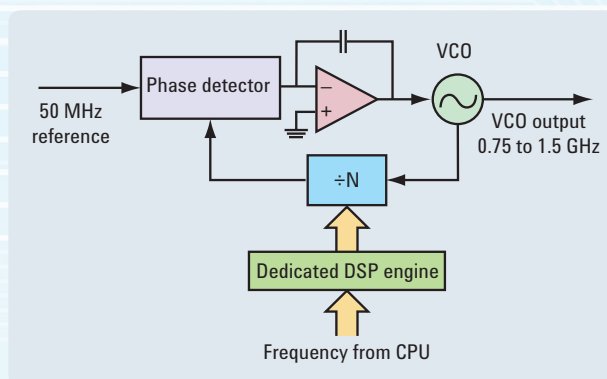

Figure 2. Simplified block diagram of the frequency synthesizer.

1. The primary contribution of the new synthesizer is in speed and phase noise. Although ACPR performance can also be affected by synthesizer phase noise, particularly at offsets of 1 MHz or more, other signal generator factors are more significant than the synthesizer in determining ACPR.

The Agilent MXG uses a voltage-controlled oscillator (VCO) as the core oscillator. VCO technology is faster than Yttrium Iron Garnet (YIG) technology, because YIGs include slower magnetic elements with a longer time constant. Even compared to previous generation VCO-based signal generators, the Agilent MXG provides significant performance improvements.

When you enter a new frequency setting, the processor sets the voltage to the VCO and the divide number N in the Fractional-N (Frac-N) divider. The Frac-N output phase is compared to the phase of the frequency reference and an error voltage is used to adjust the VCO voltage until the frequency is synthesized to the desired value. The time required to achieve phase lock depends on the loop bandwidth. Normally a wider loop bandwidth (fast) will result in phase noise which adds to the inherent phase noise of the VCO. This is commonly referred to as the phase noise pedestal, shown as an example in Figure 3.

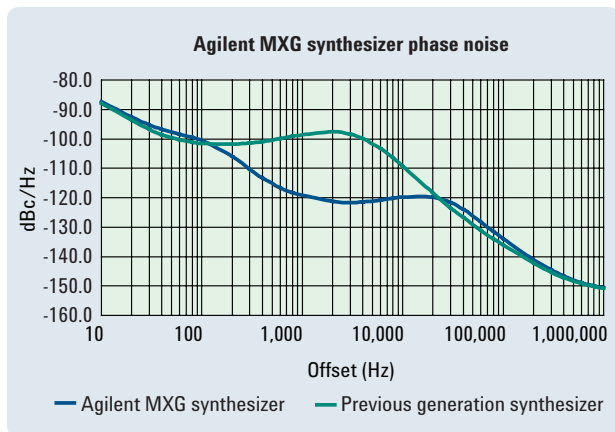

Figure 3. Agilent MXG phase noise compared to previous generation.

The Agilent MXG design actually increases PLL bandwidth and frequency switching time by a factor of ten while simultaneously decreasing the phase noise pedestal by up to 20 dB. The bandwidth increase is achieved through the use of a fast DSP to support the Frac-N divider. With faster processing speed and a higher frequency, 50 MHz reference signal (versus the 10 MHz reference used in the previous generation) lower N numbers in the Frac-N divider can be used — lower N numbers introduce less phase noise into the output signal. The Agilent MXG provides PLL performance of far more complex multiple loops but with the low cost and greater simplicity of a single-loop design. It accomplishes this with the advanced application of DSP technology in the Frac-N divider.

Faster command processing

When compared to previous generations of synthesizers, the Agilent MXG takes advantage of increased use of digital signal processing distributed throughout the instrument. This includes the advanced use of Field Programmable Gate Arrays (FPGA) for integration of key functions that in previous synthesizers included multiple discrete analog and digital processing circuits. With modern FPGAs, multiple functions can be integrated into a single program, in addition to providing flexibility and expandability for future capabilities. This also enables the system to have distributed processing so that commands can be processed in parallel and the main processor unit is not burdened with all the details. A simplified block diagram of the digital architecture is shown in Figure 4.

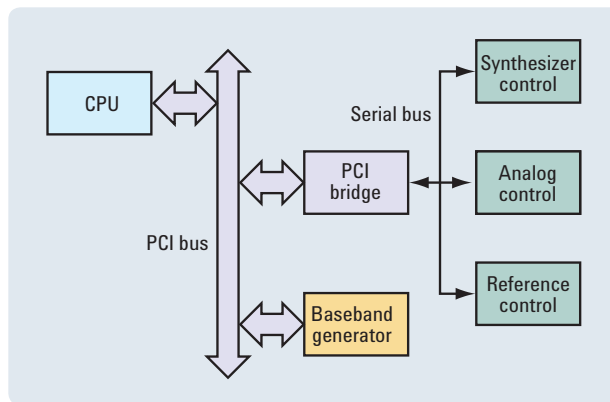

Figure 4. Simplified representation of the Agilent MXG digital architecture.

For example, when using list mode, amplitude and frequency processing can be done in parallel. When a list is set up, the coefficients for operation of the synthesizer (for frequency) and the Automatic Leveling Control (ALC) (for amplitude) are pre-configured. When the signal generator is programmed to a new point in the list, the coefficients are immediately available and the process of executing the command is streamlined. The frequency and amplitude functions are accomplished in parallel to the extent possible.

In the Agilent MXG, FPGAs are used for the following functions:

- A PCI bridge FPGA coordinates the communication between the main processor unit and all other functions requiring digital control
- An analog interface FPGA provides digital controls for the analog circuitry on board the instrument, such as ALC and divider circuits
- A reference FPGA drives the control of the frequency reference components such as the phase detector and reference oscillator
- A synthesizer Frac-N driver FPGA drives the control of the Frac-N circuits to ensure high resolution frequency setting
- A baseband ARB FPGA controls the baseband arbitrary waveform functions and interfaces to the baseband memory and the resampling ASIC

Digital control is provided for all key building block elements. The serial bus allows delivery of hardware setting commands, even for complex hardware, in just a few microseconds. The FPGAs are coordinated among themselves by sharing a common inter-FPGA communication protocol. This allows the system to optimize speed.

The use of faster hardware and smarter firmware controls are additional factors that enable faster switching speeds. The hardware includes the use of all solid state switching and attenuation. With no mechanical moving parts, the speed and reliability are both improved. The electronic attenuator is a proprietary Agilent design that incorporates up to 100 dB attenuation and very fast response.

By reducing dead time and wait states, and taking advantage of the distributed processing capabilities, the Agilent MXG firmware is

also optimized for speed. In this case, with total switching time below 1 ms, there is greater awareness and visibility of time-consuming tasks. For example, to set the status bits in the instrument takes about 50 microseconds. In some cases, it may be possible to allow the user to bypass these time-consuming steps if they are not needed. The user can set the instrument to a mode where the status bits are not set between frequency points, and the effective switching time can be further reduced.

ACPR enablers

Adjacent Channel Power Ratio is a key factor in modern digital RF communication systems. Poor performance can introduce bit errors in mobile receivers. The Agilent MXG enables industry leading performance over 70 dB for W-CDMA mobile communications signals. For more information about ACPR, see the Agilent application note: *Highly Accurate Amplifier ACLR and ACPR Testing with the Agilent MXG Vector Signal Generator*.

Key factors affecting ACPR performance are noise and intermodulation distortion (IMD) products through the entire RF signal chain. Careful design in the Agilent MXG has ensured not only the ACPR performance quality of the original RF signal with digital modulation, but it also achieves the minimum degradation of that signal as it is processed and amplified for the signal generator output.

The simplified signal path of the RF signal chain for a digitally modulated signal is shown in Figure 5. The I-Q modulator applies digital modulation onto the RF carrier. For the purposes of this discussion, we assume that the digital inputs to the I and Q Digital-to-Analog Converters (DACs) are ideal² — that is ACPR is very high (distortion is negligible). Beginning with the DACs, however, all sources of noise and IMD must be managed carefully, because each stage may degrade the ACPR.

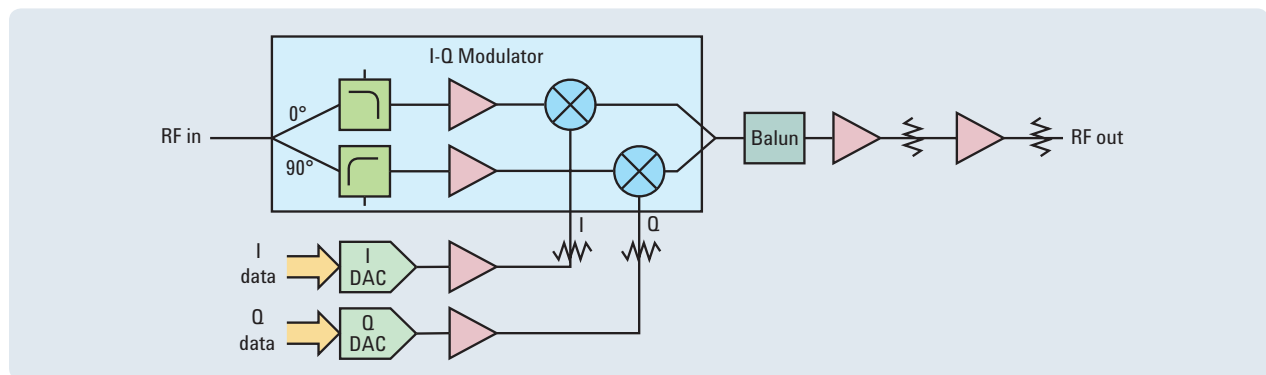

Figure 5. Simplified block diagram showing the path of a vector modulated signal.

2. The Agilent MXG I and Q signals are 16 bits. This represents 96 dB signal purity, which is far better than the expected ACPR performance (see the *Agilent N5182A MXG Vector Signal Generator Data Sheet, literature number 5989-5261EN*).

Minimizing noise and distortion

Noise and IMD are introduced in each of the active components in the chain, including the DACs, amplifiers, and modulators. If the ACPR of each stage is characterized as a function of output power, lower power levels introduce more noise and higher power levels introduce more IMD. There is typically an optimum ACPR, as shown in Figure 6.

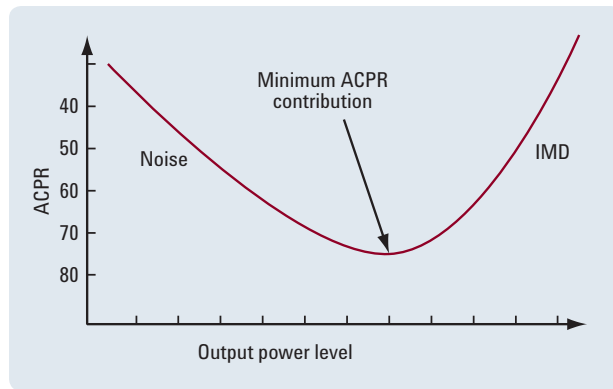

Figure 6. Sample representation of noise and IMD effects versus power level.

In the design process, this optimum point was determined using measurements of individual stages and combinations of stages. In some cases, keeping multiple stages in their optimum point makes a challenging design problem. In the case of the ALC, the output can be varied over a range of up to 20 dB. This could result in performance degradation due to noise or IMD.

Using a single sample rate

The Agilent MXG baseband generator incorporates advanced proprietary resampling technology using a custom ASIC. The role of this ASIC is to provide a constant sampling rate of 125 megasamples per second into the DACs. This constant rate allows simplified filtering and less variation in the I-Q outputs, enhancing the signal integrity and contributing to the ACPR performance. A simplified block diagram of the baseband generator with the resampler is shown in Figure 7.

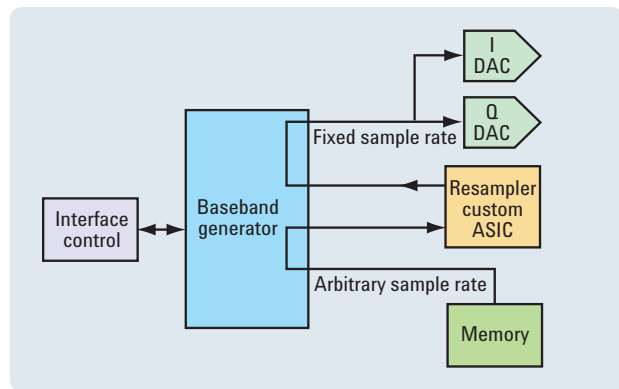

Figure 7. Simplified block diagram of the digital baseband generator in the Agilent MXG.

Some additional factors are critical to the ACPR performance of the Agilent MXG:

- I-Q modulator — The I-Q modulator is a custom integrated circuit, based on proprietary Agilent technology, which provides extremely low distortion and I-Q balance³ with frequency coverage to 6 GHz.
- Simplified I-Q signal routing — The analog I-Q signals are routed as needed with minimal signal degradation and circuit complexity. There is no I-Q multiplexing and signal processing as in previous generation instruments.
- Design process — Throughout the design process, ACPR was continuously monitored with each prototype and any issues were addressed because ACPR was maintained as a top management priority.

Cost of ownership

In addition to performance and speed improvements, the Agilent MXG offers a breakthrough in the support, verification, and maintenance process. These changes have enabled repair time of less than 30 minutes and on-site calibration in less than 60 minutes. Support logistics are greatly simplified, lowering support costs and enabling self-maintainers.

The cost of ownership enhancements are enabled by the following key factors:

- Functional layout and single-board integration
- Small number of replaceable parts (five)
- Calibration and repair strategy

3. I-Q balance is typically not a limiting factor in the ACPR performance, but is a significant factor in the Error Vector Magnitude (EVM) performance, which is often very important in digital RF applications.

Integration

When designing the Agilent MXG, the vision was to simplify the hardware implementation to control costs and lower prices. This could be accomplished with fewer printed circuit boards. In particular, it became possible to integrate key RF functionality into one multi-layer RF board, integrating the functions that required five PC boards in previous generation signal generators along with the associated interconnects and cabling. In addition to providing much greater reliability, this integration also enables breakthrough improvements in manufacturing, calibration, and repair strategies.

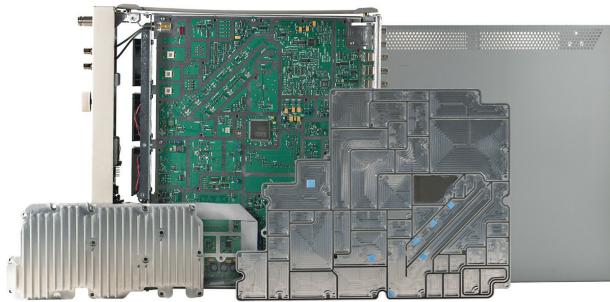

Figure 8. The discrete assemblies that make up the MXG signal generator.

The functional layout was accomplished so that all RF specifications that require measurement in performance verification — power, frequency, modulation, and so on — could be tied directly to that PC board and was completely independent of all other circuits.

Fewer parts

The full signal generator is designed with only five replaceable assemblies:

- CPU board
- Digital board
- Power supply
- RF board
- Front panel
 - Keypad
 - Display
 - Display power supply
 - Fans

This alone greatly simplifies the logistics. Troubleshooting and diagnostics are greatly simplified compared to previous generations, which had many more replaceable parts and also many more cables and interconnects which are also subject to problems. The Agilent MXG also enables economical spares kits for engineers to accomplish their own repairs and thus minimize downtime.

Calibration and repair strategy

The Agilent repair strategy is orchestrated to take advantage of the design implementation. All repair assemblies are pre-tested and fully calibrated. After installation of any new repair part, the instrument is guaranteed to meet warranted specifications without adjustment. Proof of calibration certificates and data are included with the repair parts. In circumstances where ISO 17025 and ANSI Z540 are required, these are done through the Agilent service centers. Instructions for manual operation and verification using a signal analyzer and power meter are provided in product documentation. Refurbished assemblies are available to reduce repair cost.

Conclusion

The Agilent MXG signal generator provides significant advantages in many ways. It was developed by an experienced team that has thousands of person-years of experience in the design and manufacturing of industry-leading signal generators — and that experience shows. The block diagram, the manufacturing flow, the support processes, and every aspect of the project was coordinated from the beginning to produce a signal generator that not only functions perfectly, but is also easy and inexpensive to maintain. There simply is no better product on the market.

References

United States Patent 5,694,093, Wideband I-Q Modulator with RC/CR Automatic Quadrature Network, Marcus K. DaSilva and Andrew M. Teetzel

Highly Accurate Amplifier ACLR and ACPR Testing with the Agilent MXG Vector Signal Generator, Application Note, Literature number 5989-5471EN

Improving Throughput with Fast RF Signal Generator Switching System Throughput, Application note, Literature number 5989-5487EN

Agilent N5181A MXG Signal Generator, Data Sheet, Literature number 5989-5311EN

Agilent N5182A MXG Vector Signal Generator, Data Sheet, Literature number 5989-5261EN

Signal Sources Back to Basics Seminar, http://www.home.agilent.com/upload/cmc_upload/All/BTB_Sources_2005.pdf

Click

The Evolution of RF/Microwave Network Analyzers

Roger Stancliff

New Business Research Manager, Agilent Technologies
roger_stancliff@agilent.com

Joel Dunsmore

R&D Master Engineer, Agilent Technologies
joel_dunsmore@agilent.com

Precision measurement leads to improved components and systems

The RF/microwave network analyzer has enabled the evolution of high frequency components and how they are designed. The basic ability to measure transmission, reflection, and impedance properties of circuits and devices enables engineers to optimize the performance of amplifiers, frequency converters, signal separation and filtering devices, and other components. The performance of communications and defense systems depends heavily on the capabilities of these components and their test systems.

Looking to the past

In the 1940s and 1950s most high frequency communication systems used tubes (klystron, magnetron) and AM or FM modulation techniques. Rudimentary signal generators, power detectors, and impedance bridges were used to measure the transmission, reflection, and impedance characteristics of these elements to enable successful systems to be built. To construct a modern day Smith Chart, hours of tedious, hand-tuned measurements were taken one frequency at a time. The network analyzer of the day was a swept scalar analyzer combined with tedious, point by point reconstruction of the relative phase characteristics of devices.

By the 1960s, semiconductor technology was just taking hold. Samplers based on semiconductor diodes became the fundamental building blocks of instrumentation. These were used to sample waveforms and enable relative amplitude and phase measurements to be made on signals. Agile signal sources based on backward wave oscillators allowed measurements to be taken across a wide frequency range. The first network analyzer capable of swept amplitude and phase measurements was the 8407* RF network analyzer based on the 8405 vector voltmeter. It allowed comparison of the amplitude and phase of two waveforms but it operated only up to 110 MHz. This was the year that Agilent Technologies, Inc. was spun out of Hewlett-Packard as an independent company.



Figure 1. 8410 network analyzer

In 1967 Hewlett-Packard, predecessor to Agilent Technologies, introduced the 8410 network analyzer which extended swept capability to 12 GHz. This was a bench-top system based on multiple boxes which were integrated to perform the network analysis function (Figure 1). At the same time, the concept of S-parameters was just becoming popular. This put transmission, reflection, and impedance into a single two-dimensional representation which could be rapidly measured and visualized. This was a revolution in high frequency design and enabled engineers to begin designing with the new high frequency semiconductors which were just becoming available. These devices had marginal gain and would not have been very useful without a design and measurement approach that allowed designers to extract all of what was available in these new devices. The interplay and bootstrapping of good measurements, to get the best performance from the devices, helped them both move forward.

*All products mentioned in this article prior to 2000 were sold under the Hewlett-Packard name. This was the year that Agilent Technologies, Inc. was spun out of Hewlett-Packard as an independent company.

By 1970, computers were emerging that could expand instrument capabilities (Figure 2). The 8542 automatic network analyzer was created. This large, three-rack system brought error correction mathematics, pulsed measurements, and other capabilities to circuit designers. The system, though, was three racks of equipment. Modern network analyzers realize all of this capability in a single bench-top box.



Figure 2. 8542 automatic network analyzer system

In 1976 the first integrated, microprocessor controlled network analyzer was introduced: the 8505. This included the synthesized source, receivers, test set, and display in a bench-top box, and it operated up to 1.3 GHz.

In the mid 1980s, the marriage of broadband solid state sources, improved samplers, and microprocessors led to three very important products: the 8510, 8753, and 8720 vector network analyzers (VNA). The 8510 (Figure 3) became the metrology standard for microwave measurements and enabled many improvements in component design. The 8753 (Figure 4) came to market just as manufacturing demands for first generation cell phones were growing. The 8753A was the first fully error-corrected RF network analyzer, and because of its low cost and high capability, it quickly became the industry standard. It was used extensively in wireless component manufacturing, just as the 8510 and 8720 became mainstays for avionics and radar component development and manufacturing.

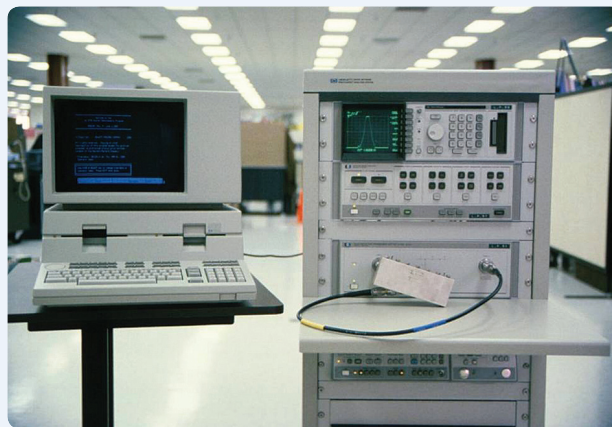

Figure 3. 8510 network analyzer

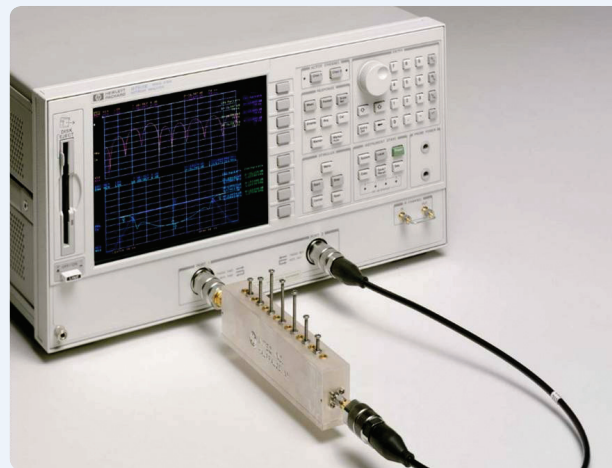

Figure 4. 8753 network analyzer

Emerging at this same time were the first commercial CAE tools for high frequency designers. The interplay between simulation and measurement allowed for acceleration of design cycles and technological capabilities. The first commercial microwave ICs emerged at this time, greatly helped by this measurement and simulation capability. The 8720 was the first fully integrated (one box) microwave VNA and it embodied most of the 8542 ANA's capability in this form factor, 20 years after the 8542 was introduced.

The 1990s saw a huge boom in wireless device deployment. This was the first high frequency consumer market with the commensurate cost pressures and manufacturing volumes. The network analyzer, once an R&D tool, became a mainstream manufacturing device. Speed of measurement became very important. During this time the 84000 RF IC tester was introduced (Figure 5). This was a multifunction, very fast, network analyzer. In some ways, just as

in the case of the 8542 automatic network analyzer of 1970, this multiple box IC test system introduced new capabilities which are just beginning their migration into the bench-top network analyzers of today and the future.



Figure 5. 84000 RFIC test system

Current technology

Since 2000, the integration level of RF and microwave devices has expanded rapidly; this new level of integration places new demands on test equipment. This has resulted in the evolution of the network analyzer from a 2-port, swept frequency, measurement instrument into one with much broader capabilities. As early as the late 1990s commercial RF components started using balanced (differential) topology to take advantage of lower power requirements and higher isolation. A key improvement for testing these devices came in 2001 with the introduction of the 4-port ENA (E5071A), the first 4-port network analyzer designed for the mass production market. The latest version (E5071C) is shown in Figure 6.

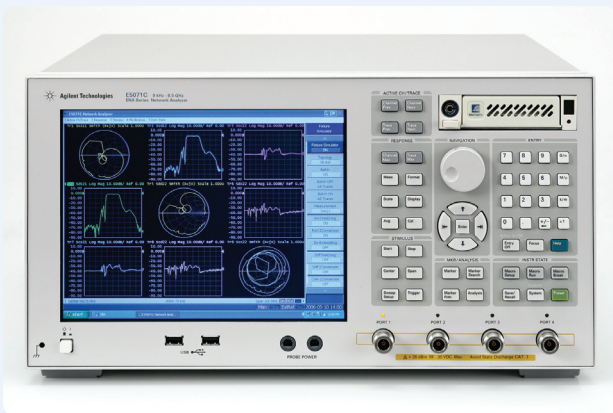

Figure 6. Agilent E5071C ENA network analyzer

This provided a simulated balun and mixed-mode S-parameters, bringing balanced measurements fully into the RF world. By 2006 the test requirements for balanced measurements extended far into the microwave region, with solutions in the PNA family providing this capability up to 67 GHz. Undoubtedly, these test techniques will need to be extended to even higher frequencies.

A new level of integration in wireless design may combine many of these components, balanced and single-ended, into package-scale integration with a large number of input/output (I/O) ports. While the overall response of this component must meet the same criteria as a design comprised of discrete components, the performance of individual elements in an IC, particularly with respect to isolation, may be degraded. As such, it is very important that the I/O ports be properly terminated, and that mismatch effects at every port be accounted for. We could combine 2- or even 4-port corrected measurements, but this requires properly terminating every other port. The number of measurements grows as N-squared, so with higher port counts this quickly becomes impractical.

Recently, a new generation of test sets have been introduced, which extends the port count of a network analyzer. These N-port systems (Figure 7) use internal switches and couplers to seamlessly integrate the test set with the analyzer giving the N-port test set performance that is directly comparable to that of 2- or 4-port systems. At this time, 8- and 12-port versions of N-port network analyzers are shipping, with 16- and 32-port systems on the horizon.

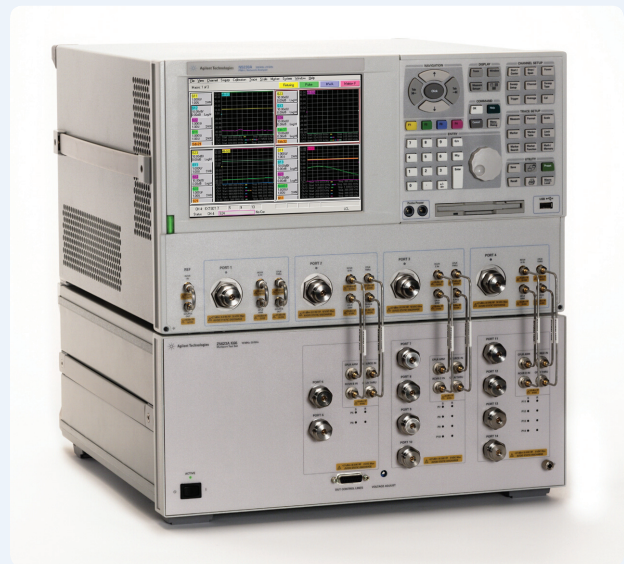

Figure 7. PNA multi-port system

Calibrating this instrument is time-consuming if done conventionally. However, techniques have been developed to greatly shorten the calibration process, including using electronic calibration modules (Ecal), without compromising measurement quality, providing a full NxN matrix of calibrated measurements with only N-connection steps. Traditional mechanical calibration requires more than N-squared steps.

In addition to the traditional S-parameter measurements, many integrated components include internal amplifiers which require characterization of noise and distortion properties. Current measurement solutions provide for a single connection of multiple-test equipment, but further integration of these advanced capabilities into a single platform is inevitable. The 84000 tester of the 1990s had many of these capabilities and, like the evolution of the network analyzer from the 8542 to the 8720, we see the emergence of new bench-top instruments which embody most of the 84000 capabilities. The challenge to this component-analyzer is to provide a sufficiently good measurement across a wide range of requirements: A network analyzer requires a very fast sweeping source, but this fundamentally conflicts with creating a source with good phase noise and low distortion required for intermodulation measurements.

The wide dynamic range of a network analyzer receiver, which is achieved through the use of narrow receiver bandwidths, is in conflict with the wide bandwidth required for noise measurements. All this gets further complicated since many of the mobile-communications systems are time-domain-duplexed, creating pulsed measurement requirements. And these devices may include frequency conversion, as well as balanced inputs or outputs. All of these challenges must be met without giving up the crucial requirement of fast measurement throughput.

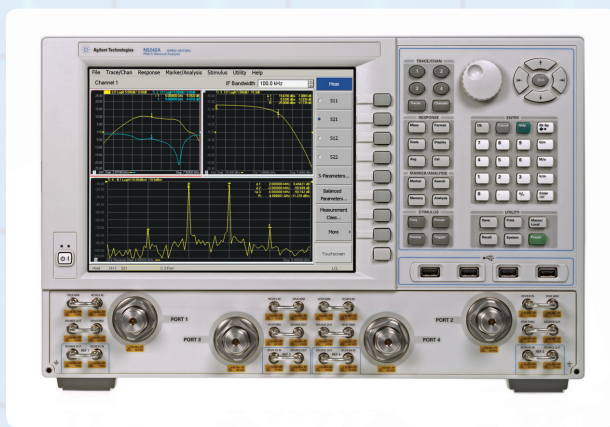

Figure 8. PNA-X component analyzer

Finally, each of these measurements must be calibrated to ensure consistent, repeatable and traceable results. The foundation to solving these challenges is being met by Agilent's new PNA-X network analyzer. The PNA-X (Figure 8) is leading a transformation in enhancing the functionality of a network analyzer to include measurements beyond traditional S-parameters.

Looking to the future

The synergy of combining a traditional network analyzer with more complex stimulus-response test systems provides improvement in the overall accuracy and correction of results, because the network analyzer function allows characterizing the mismatch and interaction between the test equipment and the device-under-test. At the same time, the types of stimulus are evolving to include complex modulation, noise, and even DC parametric drive. The responses measured are becoming much more complex, requiring sophisticated post processing of data. Thus, the integration of multifunction components into a single DUT will drive the integration of multi-function test into a single, coherent test system.

New applications, such as the frequency converter application in the PNA, which provided the first fully corrected vector mixer calibration will continue to improve, extending to such areas as measurement of converters with an embedded local oscillator, and digital RF, where components have a digital interface for one port and an RF interface for the other. Components such as these will require marrying the capabilities of today's logic and protocol analyzers with RF signal sources and spectrum analyzers.

Just as the communications networks are becoming more distributed, there is a drive to distribute testing throughout these systems. Portable and hand-held instrumentation will be required to service and support these systems; these small instruments will need a level of capability previously found only in multi-box systems. The capability of these multi-box systems will need to be distributed across these far-flung networks, perhaps even becoming embedded in them. Technologies such as IEEE standard 1588 precision time protocol will allow synchronization of data and triggering across these networks.

One might be tempted to conclude that the need for parametric test could disappear. Why not do a functional test on every component? In fact, while functional test will provide a convenient pass/fail test that could be used at the end of a production process, the functions that must be verified may become so complex that true functional test is not practical to ensure that every unit will work in all environments. For example, the input filter of a radio system is designed to remove interfering signals. A functional test to verify the correct operation of the system in the presence of other signals might mean creating every possible scenario of interfering signal, and testing the bit error rate (BER). A more efficient way of verifying this system might be to apply a swept sine to the input of the system and determine the cut-off characteristics of the filter. But, as the interfaces between components become more difficult to access, new ways of validating designs and controlling manufacturing processes will be required.

Today, it is possible to embed an Agilent logic analyzer into an FPGA design. In the future, complex stimulus/response capability, or even an entire network analyzer may be designed directly into RF circuits, providing the ultimate realization of design for test. As interfaces between components become more complex, and more difficult to probe, it seems that integrated component test may be the only logical solution to verify future generations of RF and microwave systems.

Conclusion

We have postulated that components and network analyzers helped bootstrap each other to accelerate technological progress. Going forward, this bootstrapping is increasingly happening between simulation and embedded test inside the chips themselves. The network analyzer will be used to determine the fundamental characteristics of the chip's building blocks to feed simulation engines and to verify the chip and embedded test instrument designs.

Large opportunities for stimulus/response characterization — the forte of network analyzers — also exist outside of the electronic device world in measuring attributes of materials, even down to the nanometer scale. The growth of these new applications and measurements will keep the network analyzer an essential tool for many years to come.

A Very Brief History of Network Analyzer Calibration

Ken Wong

R&D, Calibration Technology, Agilent Technologies
ken_wong@agilent.com

Network analyzers — being vector measuring instruments — have the unique ability to apply error correction techniques to improve their accuracy. Initially, short circuits were used to establish the maximum level of reflection magnitude. Precision transmission lines, sliding loads, and sliding shorts were used as impedance standards. Precision attenuators, such as piston and rotary vane variable attenuators, were used to establish transmission loss reference levels. Grease pencils were used to mark the reference level on a CRT display or meter display. Such calibration methods were able to remove some of the measurement scalar errors. The 8407 and 8410 swept frequency vector network analyzers made it possible to correct some of the vector errors. The 8542 made full vector error correction possible for the first time. It also allowed imperfect standards, such as the open-standard, to be defined by a device model. The short-open-load-through calibration method was fully enabled.

A surge in research on VNA calibration methods brought us the through-reflect-line family of calibrations, which was implemented in the 8510. Measurement accuracy became limited by the accuracy of the calibration standards. Thus, ultra-precision reference transmission lines and slotless female contacts were introduced. Electronic calibration was invented to simplify calibration; a single connection and a software controlled sequence completed the process. Multi-port, differential, and non-linear calibration methods and standards are the current challenges.

Agilent *Inside*

Agilent's Advanced High-Frequency IC Technology

Proprietary high-frequency ICs, packaging, and models enable premier measurement capability and innovation

Agilent Technologies continues to fabricate many of its own compound semiconductor ICs because they provide a competitive advantage and result in the best possible measurement products. The primary RF and microwave performance features and key specifications of Agilent instruments are often made possible by custom technology developed and manufactured in the compound semiconductor fab in Santa Rosa, California. In addition, the microwave IC fabrication capability enables higher levels of integration than can be achieved with the more conventional microelectronic assembly techniques, resulting in lower manufacturing costs along with improved performance and quality. While this article focuses mainly on semiconductor fabrication, it also touches on some of the industry-leading expertise in IC design, modeling, interconnect/packaging, microelectronics, and nanofabrication developed by Agilent's Santa Rosa, California technology center.

Derry Hornbuckle

*R&D Engineer, Agilent Technologies,
derry_hornbuckle@agilent.com*

Don D'Avanzo, Ph.D.

*R&D Project Manager, Agilent Technologies,
don_davanzo@agilent.com*

Daniel Thomasson, Ph.D.

*R&D Section Manager, Agilent Technologies,
daniel_thomasson@agilent.com*

Agilent continues to operate the internal fabrication facility because it contributes to key specifications that enable Agilent measurement solutions, because the technology is not available elsewhere to meet those needs, and because it is affordable relative to the returns. Here are some of the ways those three criteria have been met, with examples of technology contributions from the past and the present, along with projections for the future.

Contributing to key specifications

Contributing to key specifications which enable new measurement solutions is the primary motivation for the development of proprietary components. This has been the focus of Agilent's Santa Rosa, California technology center since its beginnings in the late 1960s, when microwave bipolar transistors and thin-film circuits made possible solid-state signal sources with reliability unmatched by the backward-wave oscillator tube sources of the day.

Past contributions

GaAs FETs in the 1970s increased output power and extended frequencies. In the 1980s, GaAs ICs enabled Agilent's first gigasample real-time oscilloscope (see the article "Analog-to-Digital Converters" in this issue), and GaAs diode ICs made possible millimeter-wave down-converters. Bipolar GaAs ICs in the 1990s lowered costs and enabled new and more effective block diagrams (for example, surface-mounted frequency divider chips provided an inexpensive alternative to sampler microcircuits) and made possible complex functions such as oscilloscope triggers operating well into the microwave frequency range.

Present contributions

Today, indium phosphide (InP) bipolar ICs¹ have made possible the world's first broadband clock-recovery capability in digital communications analyzers² (see Figure 1), and dramatically improved the cost competitiveness of microwave network analyzers³. GaAs FET ICs are providing world-leading adjacent-channel leakage ratios (ACLR), a key communication system specification, in microwave sources⁴ (see Figure 2). Pseudomorphic high electron mobility transistor (PHEMT) ICs make possible higher output power than previously available in millimeter-wave sources, up to 67 GHz. Numerous process capabilities underlie these semiconductor contributions, including molecular beam epitaxial growth of crystal layers, electron beam lithography, metal and dielectric processes, design, characterization, modeling, reliability testing, and more.

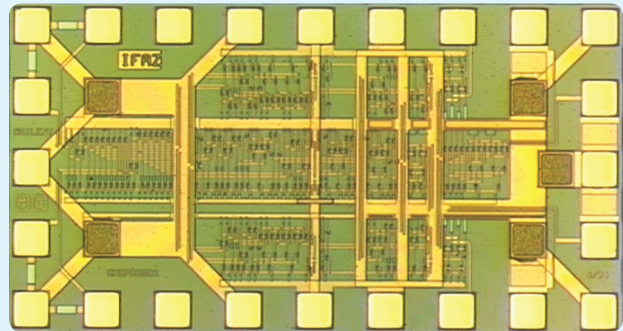

Figure 1. Continuous phase detector IC; the design uses 200 GHz ft InP bipolar process.

Agilent owns an internal semiconductor fab that is dedicated to measurement technologies. The company retains this capability because it contributes to key product specifications, the technology is unavailable elsewhere, and there is a good return on the investment.

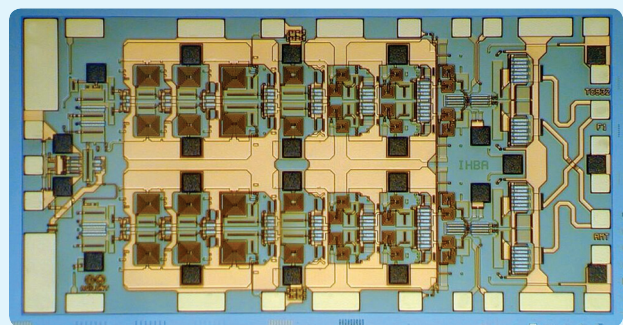

Figure 2. I-Q modulator IC designed for the Agilent Technologies N5182 MXG vector signal generator.

Looking beyond the semiconductor components, improved models for both FET⁵ and bipolar⁶ compound semiconductors developed initially for internal use, are now important elements of Agilent's Advanced Design System (ADS). Surface-mount packages⁷ provide performance beyond 30 GHz with dramatically lower manufacturing costs than microcircuits in machined packages (see Figure 3). Chip-and-wire assemblies on printed circuit boards, with custom shielding and interconnects, combine dozens of ICs into precision, cost-effective front-ends for microwave spectrum analyzers.

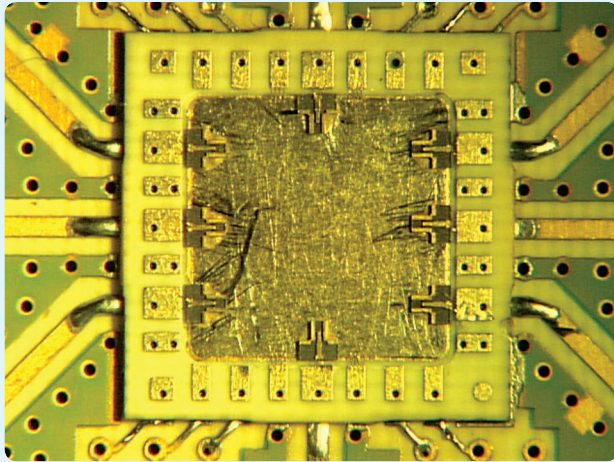

Figure 3. Millimeter-wave surface mount package designed for multiple applications. Package accommodates three to six ICs; this photo shows thin-film loads used for characterization.

Agilent's unique combination of measurement science and measurement technology expertise has been critical to the success of such market-differentiating components (of which the preceding examples represents a small sampling). Many of the technologies and components were initially developed at Agilent Laboratories, and every technology innovation involved numerous people across Agilent's businesses in addition to those in the technology center.

Future contributions

Here are some of our projections for future component contributions:

- Semiconductor process developments will enable higher levels of integration, lowering costs. Although the level of integration for microwave ICs is sometimes limited by the requirement for off-chip components such as filters and baluns, more complex ICs can contribute to performance in other ways as well, such as automatic gain and impedance control for greater precision in measurements.

- Continuing advances in materials technology promise to provide even higher microwave performance.
- Neural network mathematics will enable device models with unmatched accuracy, reducing design iterations in the development of new components.
- Improved system-level models will speed development of instrument block diagrams, and become essential elements of Agilent electronic design automation products.
- New solutions for switch technologies will make possible lower-distortion signals and new instrument block diagrams.

The question of whether future capabilities such as these are developed internally or not depends on the second criteria for proprietary component investment — external technology availability.

Technology unavailable elsewhere

Because commercial IC manufacturers focus on lower-cost, high-volume applications, they generally do not offer instrument-grade technologies, which must simultaneously deliver higher performance and extreme reliability. Agilent instruments are used to characterize the current and next generation of electronic devices, so instrument performance must exceed the performance of components on the market, and therefore utilize more advanced technology which is usually not commercially available when it is needed. In addition, Agilent customers expect instruments to continue functioning reliably over a long lifetime, often in excess of 20 years, in contrast to the less stringent requirements for commercial components built into short-lived products like cell phones. Examples of technology not available elsewhere at the time Agilent needed it are:

- Heterojunction Bipolar Transistor (HBT) integrated circuits with high reliability⁸ over a 20 year instrument lifetime — commercial technology at the time used an emitter material with adequate reliability for cell phones, but not for instruments.
- GaAs ICs with better low-frequency (1/f) noise, phase noise, and reduced low-frequency anomalies relative to commercial technologies.
- Custom protection devices for reducing warranty failures due to electrostatic discharge and inadvertent reverse power damage.

Even if a commercial equivalent becomes available after Agilent's initial shipment, it has often made economic sense for Agilent to continue producing the proprietary parts based on development and qualification costs and assurance of supply considerations. There are also cases where it eventually becomes advantageous to outsource technologies, for example:

- Surface acoustic wave (SAW) and surface transverse wave (STW) devices, which provided custom filter performance unavailable elsewhere at the time for spectrum analyzers, but have since been outsourced.
- Ultra-high speed photodetectors, which were not available with the required performance at the time, but are now obtained commercially.

Outsourcing decisions like these relate to the third criterion for investment in proprietary components: cost effectiveness.

Cost effectiveness and return factor

In addition to accessing and co-developing technologies outside of Agilent to bring the best technologies to our instrument customers (capabilities beyond the scope of this article), we have found that developing unique technologies for measurement applications not only enables key instrument specifications, it also provides a good return on the investment (ROI). To maximize ROI, the technology center has successfully controlled development costs by maintaining a relatively small fabrication equipment set with state of the art capabilities, and applying modular development strategies that leverage existing technology blocks and expertise in order to focus on rapid invention and introduction of truly innovative technologies.

A rigorous technology selection process is used to determine the semiconductor platforms that have the potential to contribute the most benefit to Agilent products. During the definition phase of a new technology the target attributes are selected to maximize utilization and benefit throughout Agilent. IC platforms have spawned numerous IC product designs that have been used in many Agilent instruments. In this way the contributions of a single IC technology development are leveraged across multiple instrument products, maximizing ROI.

Conclusion

For well over 30 years, Agilent's Santa Rosa, California technology center has developed and manufactured semiconductors and related components that significantly improve the competitiveness of Agilent instruments. IC technologies including diodes, FETs, PHEMTs and HBTs in GaAs and InP have been successfully developed, along with associated designs, models, and package/interconnect capabilities. Components based on these technologies provide many of the key specifications for Agilent instruments, enable improvements to instrument block diagrams, and reduce costs, while providing instrument-level quality. Emerging developments in the technology center will continue to drive improved performance, functionality, and unmatched opportunities for innovation that will contribute to future Agilent measurement solutions.

References

1. *GaAsSb DHBT IC Technology for RF and Microwave Instrumentation*, Low, T.S.; Dvorak, M.W.; Farhoud, M.; Yeats, R.E.; Iwamoto, M.; Essilfie, G.K.; Engel, T.; Keppeler, B.; Chang, J.S.C.; Hadley, J.; Patterson, G.; Kellert, F.; Moll, N.; Bahl, S.R.; Hutchinson, C.P.; Ehlers, E.; Adamski, M.E.; Culver, M.K.; D'Avanzo, D.C.; Shirley, T.; Compound Semiconductor Integrated Circuit Symposium, 2005. CSIC '05. IEEE, 30 Oct. to 2 Nov. 2005, pp. 69 to 72
2. *A Frequency Agile 40 Gb/s Half-Rate Linear Phase Detector for Data Jitter Measurement*, Karlquist, R.; Marshall, T.; Tuyl, R.V.; Hutchinson, C.; Compound Semiconductor Integrated Circuit Symposium, 2005. CSIC '05. IEEE, 30 Oct. to 2 Nov. 2005, pp. 33 to 36
3. *Enabling Components for Low Cost and High Performance Network Analysis*, E. Ehlers, C. Hutchinson, and B. Wong, to be presented at 2007 Agilent Technology Conference
4. An earlier, related I-Q modulator is described in *A Stable 250 to 4000 MHz GaAs IQ Modulator IC* Teetzel, A.; Solid-State Circuits Conference, 1997. Digest of Technical Papers. 44th ISSCC., 1997 IEEE International, 6 to 8 Feb. 1997, pp. 364 to 365, 486
5. *Technology Independent Non Quasi-Static FET Models by Direct Construction from Automatically Characterized Device Data*, Root, D.E., Fan, S., Meyer, J., 21st European Microwave Conf. Proceedings, Stuttgart, Germany, Sept 1991, pp. 927 to 932
6. *Large-Signal HBT Model with Improved Collector Transit Time Formulation for GaAs and InP Technologies*, Iwamoto, M.; Root, D.E.; Scott, J.B.; Cognata, A.; Asbeck, P.M.; Hughes, B.; D'Avanzo, D.C.; Microwave Symposium Digest, 2003 IEEE MTT-S International, Volume 2, 8 to 13 June 2003, pp. 635 to 638 vol.2
7. *Low Return Loss DC to 60 GHz SMT Package with Performance Verification by Precision 50 Ohm Load*, Nicholson, D.; 2005 European Microwave Conference, Volume 1, 4 to 6 Oct. 2005
8. *Migration from an AlGaAs to an InGaP Emitter HBT IC Process for Improved Reliability*, Low, T.S.; Hutchinson, C.P.; Canfield, P.C.; Shirley, T.S.; Yeats, R.E.; Chang, J.S.C.; Essilfie, G.K.; Culver, M.K.; Whiteley, W.C.; D'Avanzo, D.C.; Pan, N.; Elliot, J.; Lutz, C.; Gallium Arsenide Integrated Circuit (GaAs IC) Symposium, 1998. Technical Digest 1998., 20th Annual, 1 to 4 Nov. 1998, pp. 153 to 156

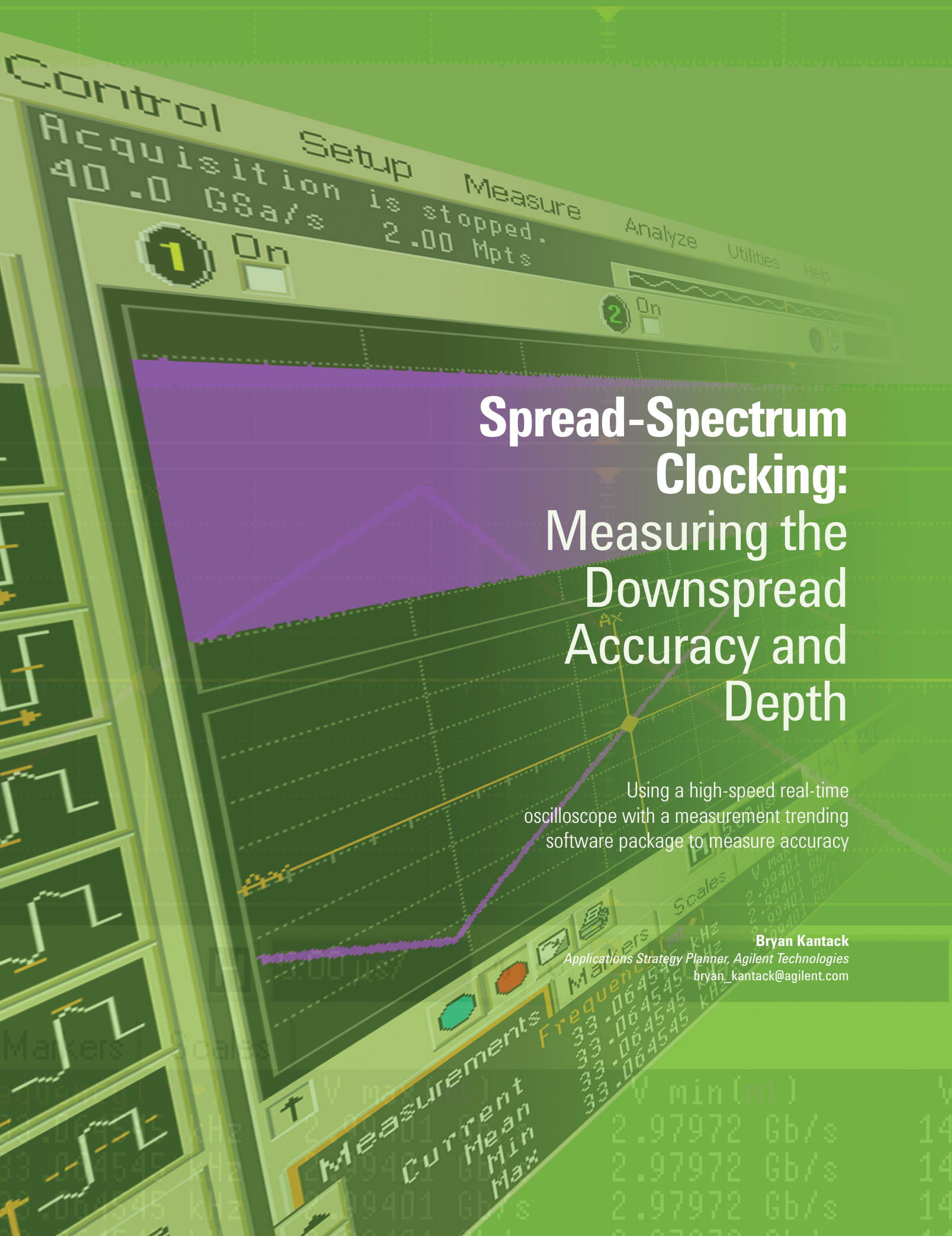

Spread-Spectrum Clocking: Measuring the Downspread Accuracy and Depth

Using a high-speed real-time oscilloscope with a measurement trending software package to measure accuracy

Bryan Kantack

Applications Strategy Planner, Agilent Technologies
bryan_kantack@agilent.com

Measurements	Frequency (MHz)	W max
Current	33.064545	2.97972 Gb/s
Mean	33.064545	2.97972 Gb/s
Min	33.064545	2.97972 Gb/s
Max	33.064545	2.97972 Gb/s

Connecting to the transmitter under test

It is important to consider the methods available for measuring a multi-gigabit signal without disrupting the signal's voltage and timing characteristics. Many designers have allotted enough space for SMA connectors on their development boards to directly measure the transmitted signal using an oscilloscope. This is usually a good practice early in chipset validation, but may not be possible once the board goes to final layout for production prototyping. At this stage it is crucial to have robust, high-performance test tools available for debugging your target system, and to allow for precision measurements at either the transmitter or the receiver end of a high-speed serial link.

Today's state-of-the-art differential active voltage probes now offer up to 13-GHz of measurement bandwidth with less than 0.22 pF of capacitive loading at the probe tip. These tools typically employ small passive test circuits, miniature connectors that attach to the device under test (DUT), and an active amplifier to transmit the signal with minimal distortion back to an oscilloscope for viewing. Figure 1 illustrates a small 13-GHz differential active voltage probe connected directly to the package pins of a high-speed differential transmitter on an active link. It is recommended that you use the highest bandwidth probing solution available to avoid inducing unwanted slew-rate limitations or artificial signal anomalies into the signal under test. Some high-speed serial link standards will additionally specify compliance test points, which are typically located at a common connector interface where the high-speed serial transmitter pair will mate with the corresponding receiver pair of a similar device to which it is connected.

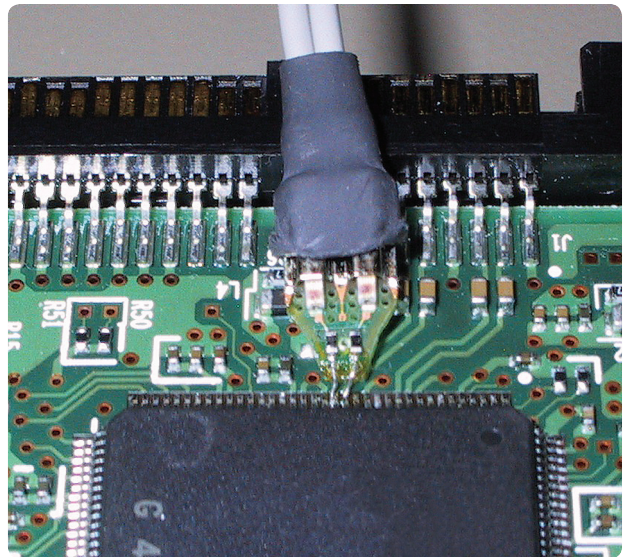

Figure 1. Differential active probe with 13-GHz bandwidth, connected to the TX package pins on a high-speed serial link.

M

Many of today's high-speed serial designs use embedded clocks to avoid the routing and timing issues involved with separate data and clock signals, and to free up precious real estate on board designs. These embedded clocks are not literally a separate clock signal that is coupled to the original data signal, but instead the clock is used to time the data transmitter output, and a separate phase-locked loop (PLL) is used to recover the clock signal from the data at the receiver. Because the data is a synchronous source of electrical energy, the clock frequency of the data is focused at half the data rate and other transition period harmonics, and creates electro-magnetic interference (EMI) at those frequencies.

Electromagnetic Compliance (EMC) labs use broad-spectrum analyzers to measure the EMI of a device in discrete bands (perhaps 120 kHz wide) when determining compliance. Many device vendors have now turned to a method of data-rate smearing called spread-spectrum clocking (SSC) to avoid having too much EMI within any one band when tested by an EMC tester. SSC further helps to reduce cross-talk between adjacent asynchronous buses in complex systems, such as personal computers or servers, where many high-speed serial peripheral buses are operating simultaneously.

SSC is implemented by frequency modulating the data transmission output of a transmitter to spread the spectral energy peaks over a wider bandwidth. The total energy on the bus is, therefore, not reduced, but spread over a wider frequency band. A PLL at the receiver then uses a closed loop high-pass filter function to track the frequency modulation of the SSC and recover the data.

An example would be the Serial ATA (SATA) electrical compliance interface, where the electrical characteristics of the transmitter are measured at the SATA connector, as it is connected to a high-quality laboratory load. Here, the laboratory load is provided by a high-bandwidth oscilloscope and reference-quality test connector having greater than 20 dB of return loss from 100 MHz to 5 GHz and greater than 10 dB of return loss from 5 GHz to 8 GHz. Figure 2 illustrates this type of laboratory load used for Serial ATA electrical performance validation and compliance testing.

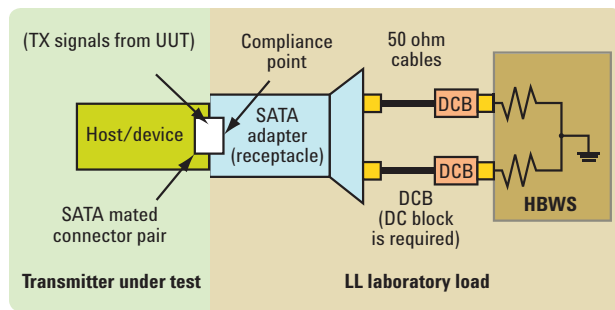

Figure 2. Serial ATA laboratory load for 3.0-Gbps SATA transmitter compliance testing.

Selecting the appropriate oscilloscope bandwidth

Once an appropriate connectivity method has been established to properly terminate and capture the signal under test, the SSC modulation depth and frequency can be measured. It is recommended that you use a repeating 1010 data pattern to test the SSC's performance, and to send the repeating data pattern at the highest supported data rate for the bus. This will ensure that the spectral content of the digital signal is focused primarily at one-half the data rate, and it reduces the effects of data-dependent jitter in the measured data rate. It is also recommended that you choose an oscilloscope with enough bandwidth to capture the fifth harmonic of the nominal data rate, and enough sample rate to avoid aliasing on a single-shot data capture.

For 3.0-Gbps Serial ATA, this would require an oscilloscope bandwidth of no less than 7.5 GHz and at least 20 GSa/s of single-shot sample rate. The Serial ATA electrical specification

recommends 10 GHz of bandwidth, and a common rule for digitizing oscilloscopes is that the minimum sample rate should be 2.5 times the oscilloscope bandwidth to avoid aliasing of frequencies near the oscilloscope's upper bandwidth limit. Several real-time oscilloscopes are now available that meet the 10 GHz and 25 GSa/s minimum requirements to most accurately measure the SSC profile of 3-Gbps data streams.

Configuring the measurement

The accuracy of a spread spectrum clock can be easily measured using a real-time oscilloscope with deep memory and a jitter measurement package capable of trending the measured time gaps between the transitions in a fast serial data stream. It is crucial that you first evaluate the repeating frequency of your SSC modulation and use a digitizing, real-time oscilloscope with enough memory to capture at least one full period of the SSC modulation frequency at its maximum sample rate — which is 40 GSa/s on today's highest bandwidth real-time oscilloscopes. For example, if you have a 33 kHz frequency modulation on a 3.0 Gbps data rate, then you will need approximately 2 Mpts of memory at 40 Gsa/s (2,000,000 samples times 25 ps/sample equals 50 μ s) to capture the 30.3 μ s modulation period of the SSC.

Figure 3 shows a 3.0 Gbps data signal (upper trace) that is being frequency modulated by a 33 kHz triangular SSC profile (lower trace). The triangular SSC profile is used to down-spread the data signal's frequency from 0 to -0.5 percent to reduce the concentration of EMI at any one frequency. This means that the data rate can be no faster than 3.0 Gbps and no slower than 2.985 Gbps, or a change of 0 MHz to -15 MHz from the nominal line rate.

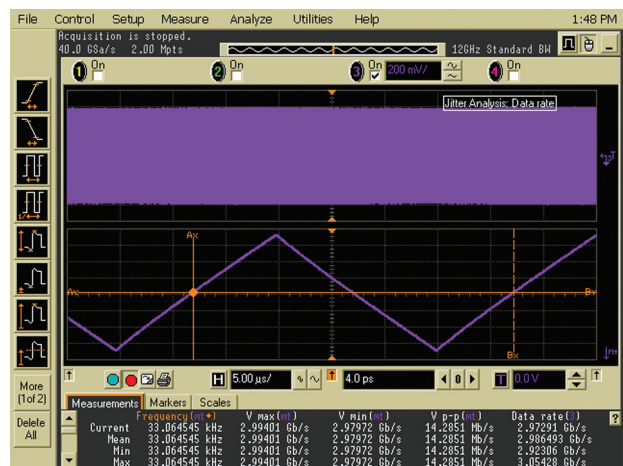

Figure 3. A 3.0-Gbps signal with a -0.5 percent frequency downspread from a 33 kHz triangular spread-spectrum clock.

A simple measurement trend of the data rate measurement built into this 13-GHz real-time oscilloscope's EZJIT measurement trending and jitter analysis software, allows you to observe the change in the data rate of the data being transmitted on this link, as well as the frequency accuracy of the 33 kHz triangular SSC profile being used to frequency modulate the data. It is important to note that a simple trend of the data rate will show all variations in the data rate due to both the SSC frequency modulation as well as short-term variations (modulation domain noise) in the data rate, which can make it very difficult to measure the SSC profile accurately. Therefore, most high-speed serial bus specifications that allow for transmitters to use SSC will specify a narrower frequency range over which the modulation depth and frequency accuracy of the SSC is measured. The Serial ATA electrical specification specifies a low-pass filter that must be applied to the measurement trend with a cutoff frequency of 60 times the maximum frequency range allowed for the triangular SSC profile, or approximately 1.98 MHz.

Applying the low-pass filter

The real-time oscilloscope that we are using offers a smoothing feature in its measurement trending software package that acts as a low pass filter for removing higher frequency variations in the data rate trend caused by sources of data-dependent jitter, random jitter, or bounded uncorrelated jitter above the desired 1.98-MHz cutoff frequency. The equation in Figure 4 is a general guideline for choosing the number of smoothing points to use in filtering the data rate measurement trend for this particular measurement trending software package.

$$\text{SmoothPts} = \frac{0.4428 * (\text{Fbaud})}{\text{DesiredCutoffFrequency}}$$

Figure 4. Equation for determining the appropriate number of smoothing points for the data rate measurement trend plot in the EZJIT measurement package, where Fbaud is the nominal bit rate of the transmitted data.

Solving for SmoothPts when measuring the SSC on a 3.0-Gbps Serial ATA link, using a 1010 data pattern (called high-frequency test pattern or HFTP) and having a desired cutoff frequency of 1.98 MHz, would yield approximately 670 smoothing points.

Measuring the SSC modulation depth and frequency accuracy

Because the measurement trend (lower trace), as shown in Figure 3, is plotting the data rate on the vertical axis versus time on the horizontal axis, it is possible to use the oscilloscope's automated amplitude measurements to measure the minimum and maximum line speed rates over an entire cycle of the spread-spectrum clock modulation period, which in this case is nominally 30.3 μ s. Additionally, the oscilloscope's automated frequency measurement can be applied to the data rate measurement trend with its thresholds adjusted to measure the frequency at the 50 percent threshold of the rising or falling edges of the filtered triangular SSC profile.

Figure 3 illustrates several automated oscilloscope measurements being used to quickly and accurately identify the maximum and minimum data rates of the measured data, as modulated by the triangular SSC profile, as well as the frequency of the SSC profile. The oscilloscope's markers are set to automatically track the frequency measurement, but could also be used to track the maximum and minimum data rate measurements. Using automated oscilloscope measurements provides significantly more accuracy when assessing the SSC's modulation depth and frequency accuracy than the traditional methods of adjusting data markers manually.

Conclusion

Correctly setting up and measuring SSC profile modulation depth and frequency accuracy has become much simpler using today's state-of-the-art high-performance oscilloscopes and automated measurement trending software.

- You must carefully choose the connectivity to the transmitter under test, and choose the appropriate bandwidth and sample rate of the oscilloscope making the measurement — to ensure that the integrity of the data signal being measured is maintained and the proper reference test load is applied.
- You must apply an appropriate low-pass filter to remove higher frequency modulation domain noise from the measurement trend — exposing only the signal characteristics of interest on the SSC profile being measured.
- Use the automated amplitude and frequency measurements from the oscilloscope's measurement menu — this provides simple and accurate measurements of maximum and minimum data rates and SSC profile frequency, providing measurement consistency and saving you valuable time for other work.

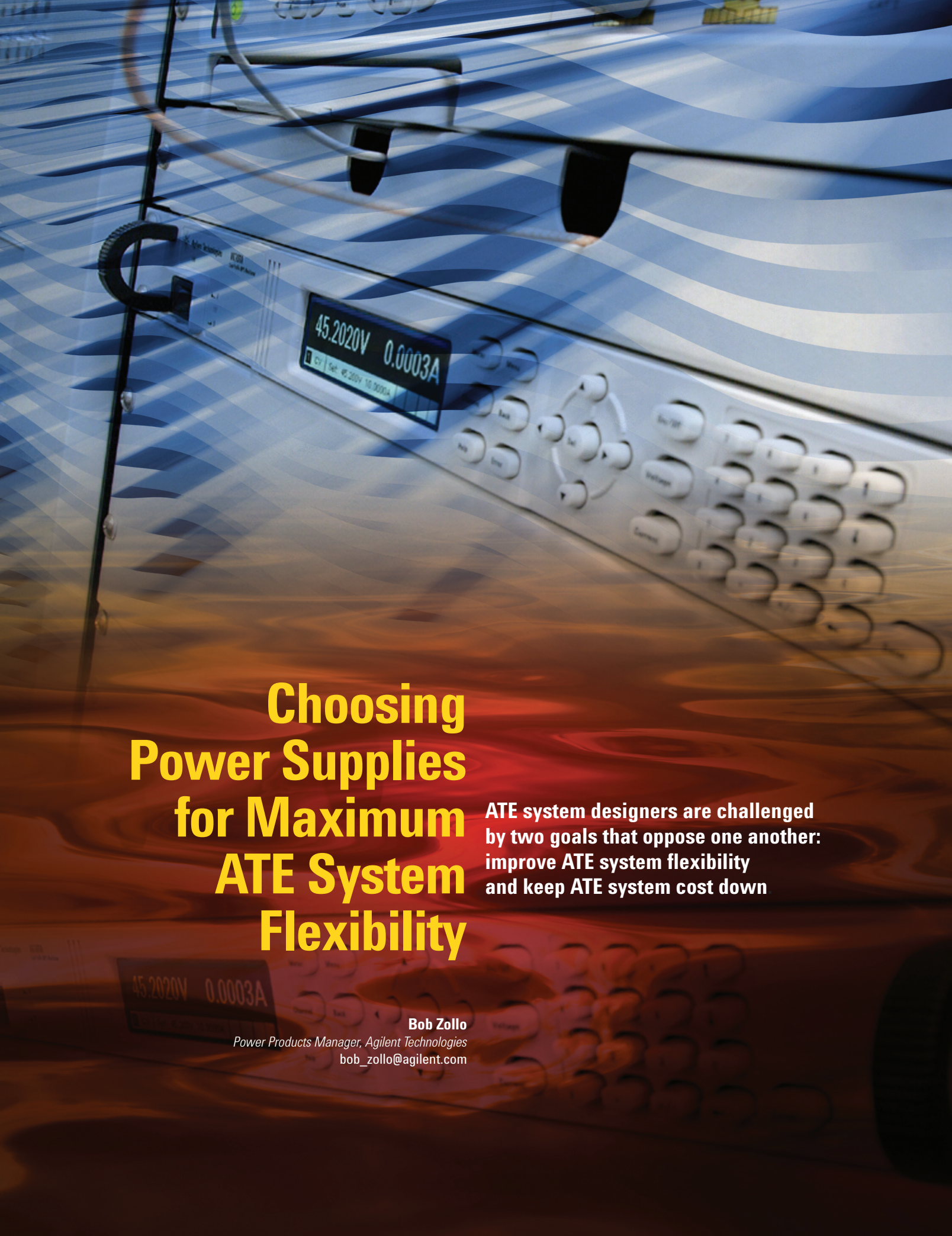

Choosing Power Supplies for Maximum ATE System Flexibility

ATE system designers are challenged by two goals that oppose one another: improve ATE system flexibility and keep ATE system cost down

Bob Zollo

Power Products Manager, Agilent Technologies
bob_zollo@agilent.com

M

Many test configurations require one medium power source and several low power sources to drive the device under test (DUT). For example, many devices require 3.3 V or 5 V at high current to power CPUs and digital electronics, while other auxiliary circuits will operate at ± 12 V and ± 24 V at very low currents. Table 1 includes several examples of this.

Table 1. Examples of devices that require multiple DC power inputs.

Device	Main power source requirements	Auxiliary power source requirements
PC motherboard	5 V, 18 A, 90 W 12 V, 6 A, 72 W 3.3 V, 14 A, 46 W	-12 V, 0.3 A, 4 W -5 V, 0.3 A, 1.5 W 5 V standby, 1.5 A, 7.5 W
Large format LCD CCFL backlight inverter	24 V, 12 A, 280 W	3 auxiliary circuits; each one at 5 V, 2 A, 10 W
Automotive ECU or body electronics	12 V for main power to the device, at currents up to 20 A or even higher	A wide variety of DC sources operating at various voltages and currents to simulate DC inputs to the device from relays, sensors, switches, etc.

A common ATE system requirement is to test a variety of DUTs on the same system to maximize utilization of capital test equipment. This requirement drives the need for maximum ATE system flexibility, which in turn creates challenges when selecting and configuring the programmable power supplies in the system. For DUTs that require multiple power sources, the combinations of voltage and current, multiplied by the number of required power supply channels per DUT, can create quite a complex and expensive configuration when trying to build an ATE system that can test many DUTs. And, if several DUTs will be tested simultaneously this increases the complexity and cost even more.

Using separate single-output power supplies

In this test configuration, you select separate single-output DC power supplies to fit the voltage and current required for each input of the DUT. Each input is powered by one channel (one output) of the DC power supply configuration. This may be the best approach when the DUT requires only one or two power sources.

If the system is designed to test multiple DUTs simultaneously, the number of required power supply channels grows quickly. And when testing DUTs that require four or more power source channels, as the number of different DUTs increases, the combinations of power supply channels that are required goes up quickly.

Some system designers attempt to reduce complexity by selecting larger power supplies. The power supplies are sized based on the maximum power needed on each channel for any DUT being tested. Thus, fewer, larger supplies can be used while still meeting the outer envelope of all power requirements. While this does reduce the number of power supplies needed, as larger supplies are selected, there are also increased difficulties with system integration because higher-power DC power supplies will be larger and take up more rack space.

Using multiple-output power supplies

In contrast to using a separate single-output DC power supplies for each channel, you may choose to use a multiple-output DC power supply, which has advantages, as described in Table 2.

In the past, the available multiple-output DC power supplies tended to be fixed-configurations. These fixed-configurations did not offer the flexibility to individually select the voltage and current combination of each output channel. Given the wide range of voltage, current, and power combinations that may be needed, it may be difficult to configure an optimized solution because both high-power and low power modules are not available in any vendor's multiple-output power supply offering. The result would mean that you will need to select outputs that are oversized on the low-power channels. Therefore, to try to construct an optimized solution based on fixed-configuration multiple-output power supplies could be difficult or impossible, thus the benefits of using a multiple-output power supply cannot be realized.

Today, several vendors offer modular, configurable systems that allow you to create your own solution with the exact number and voltage/current combinations you need. These solutions, therefore, provide for small size, reduced capital, and even the configurability to meet all of the power needs. Modular systems can also be adapted in the future as needs change by swapping in new modules. However, most modular systems on the market today are specialized instruments developed for aerospace/defense programs and may not be suitable for general purpose power supply applications.

Table 2. Advantages of multiple-output power supplies.

Goal	When using separate DC power supplies	When using a multiple-output power supply
To minimize size	Separate power supplies will be larger because of redundant elements such as one display per output, one set of user controls per output, and one computer interface per output.	A multiple-output power supply will be smaller because it combines several outputs in a single package that share a display, user controls, and computer interface.
To simplify rack mounting	Separate power supplies will need individual rack mount hardware. If the supplies are different sizes, it can be very hard to rack mount them together without complex brackets or wasted space.	A multiple-output power supply will have one package for all outputs and will be easier to rack mount.
To control the turn-on sequencing or shutdown	Separate power supplies do not behave as one and are difficult to synchronously control without complex software and/or extra cabling for triggering and synchronization signals. Sequence timing is dependent on software and on PC clock speed. When fast shutdown on faults is required, the PC will need to constantly monitor the outputs so that when it detects a fault in one supply, it can then shut down the remaining outputs.	Some multiple-output power supplies can be programmed to turn on/off in sequence, reliably and repeatedly, without software timing dependence. When a fault occurs on one output, the supply can immediately shut down other outputs within the same multiple-output instrument without requiring the PC to monitor and respond.

When selecting a multiple-output power supply, you need to size each power supply to match the DC power requirements of the DUT. This means that the multiple-output DC power supply should be modular and allow you to pick modules of different power levels to match the individual DC input requirements of the DUT. By selecting the right modules, the result can be a multiple-output DC power supply with one or two medium power channels and several low power channels.

Given the wide range of power needed for the various inputs within each of the individual DUTs in Table 1, it may be difficult to configure an optimized solution because both high power and low power modules are not available in any vendor’s multiple-output power supply offering.

Configuring a solution for testing an LCD backlight inverter

Let us look at an example where the DUT is an LCD backlight inverter, requiring 280 W on its main input, and 10 W each on three auxiliary inputs. The total power requirement is 310 W.

- The ATE system designer chooses to use a multiple-output power supply that is modular.
- There are three module power levels to choose from: 100 W, 200 W, and 400 W.
- There are two power mainframes to choose from: a smaller one that can support 500 W of total module power and a larger one that can support 2000 W of total module power.

- To test the LCD backlight inverter, the designer will select a configuration of one 400 W and three 100 W modules. This is 700 W of module power.
- The 2000 W mainframe will be needed to support 700 W of total module power.

Although a configuration has been selected that meets the power requirements of the DUT, this solution has many drawbacks:

- The designer will be forced into buying a 2000 W mainframe to support 700 W of total module power, even though the DUT only requires 330 W.
- The 2000 W mainframe will be larger than the 500 W mainframe, thus increasing ATE system size.
- The 2000 W mainframe will require additional AC power impacting the AC power distribution within the ATE system, and possibly driving the need for a separate high power AC main circuit.
- The 2000 W mainframe will generate additional heat.
- The overall system will be more expensive because the ATE system designer has been forced to buy over six times more power than needed (2000 W to test a 310 W DUT).

Some power supply vendors will allow you to configure a multiple-output power supply where the sum of the module power exceeds the power that is available in the mainframe. These power supply mainframes will allow the modules to draw combined power up to the maximum power available from the mainframe, but when the sum of the power drawn from the modules exceeds the power

in the mainframe, the power supply will operate in an extended power condition for a short while, after which it will shutdown in an uncontrolled manner. This is an undesirable event when operating in an ATE environment.

A better solution through power management

Agilent Technologies offers the Agilent N6700 low-profile modular power system. This instrument is a DC power supply system specifically designed to meet the needs of a broad range of ATE systems and applications. This small, flexible, and fast power system consists of a 1U, 4-slot mainframe and modules. There are three mainframes and 20 modules to choose from (see Table 3).

Table 3. The Agilent N6700 low-profile modular power system.

Mainframes	N6700B: 1U, 4-slot, 400 W total output power N6701A: 1U, 4-slot, 600 W total output power N6702A: 1U, 4-slot, 1200 W total output power
Modules	Each module takes 1 slot N6730 family of 50 W basic DC power modules N6740 family of 100 W basic DC power modules N6770 family of 300 W basic DC power modules N6750 family of 50 W and 100 W high-performance, autoranging DC power modules N6760 family of 50 W and 100 W precision DC power modules

As you can see from Table 3, the Agilent N6700 is ideal for use in an ATE system. With four outputs of up to 300 W per output in 1U of rack space, the Agilent N6700 takes less space in the rack, leaving more space for other instrumentation. And thanks to its wide variety of modules, you can configure a solution to fit the needs of the DUT.

Using the Agilent N6700

Now, let us look at that same example but using the Agilent N6700:

- There are three module power levels to choose from: 50 W, 100 W, and 300 W.
- There are three power mainframes to choose from: 400 W, 600 W, 1200 W.
- To test the LCD backlight inverter, the configuration will be one 300 W module and three 50 W modules. This is 450 W total of module power.

The Agilent N6700B 400 W mainframe can be selected, even though there is 450 W worth of module power, thanks to a unique feature in the Agilent N6700 power management. The firmware in

the mainframe allows you to allocate the mainframe's power to the modules that need it, while taking power away from the modules that do not need it. In this example, the 300 W module will be allocated its full 300 W (used to test the 280 W main input) while you limit the remaining three channels to 30 W per channel (used to test the 10 W auxiliary circuits).

Power allocation allows you to select a lower power mainframe for this application, with the following beneficial results:

- The lower power mainframe will require less AC power than in the previous example where more AC power was needed for the 2000 W mainframe.
- The lower power mainframe will generate less heat than in the previous example compared to heat generated by the 2000 W mainframe.
- The overall system will be less expensive because you can make full use of the mainframe power resource and you are not forced to buy more power than needed.
- Because the power allocation feature is controlled via software, the Agilent N6700 can be easily reprogrammed to allocate the power in a different manner for a different DUT.
- If the DUT draws more power than is allocated on any channel, that channel will go into power limit, but the mainframe itself and other channels will continue to function properly. Therefore, unexpected and uncontrolled mainframe shutdown does not occur.

Conclusion

A modular, multiple-output power supply can be a first step toward keeping system costs down by minimizing power supply size and complexity compared to using several single output power supplies. Multiple-output power supplies with modern firmware-based power allocation features can further reduce the cost and size of the power supply by allowing for better utilization of the power supply asset. Power allocation firmware is available in the Agilent N6700, allowing you to further drive down system costs while still achieving maximum flexibility.

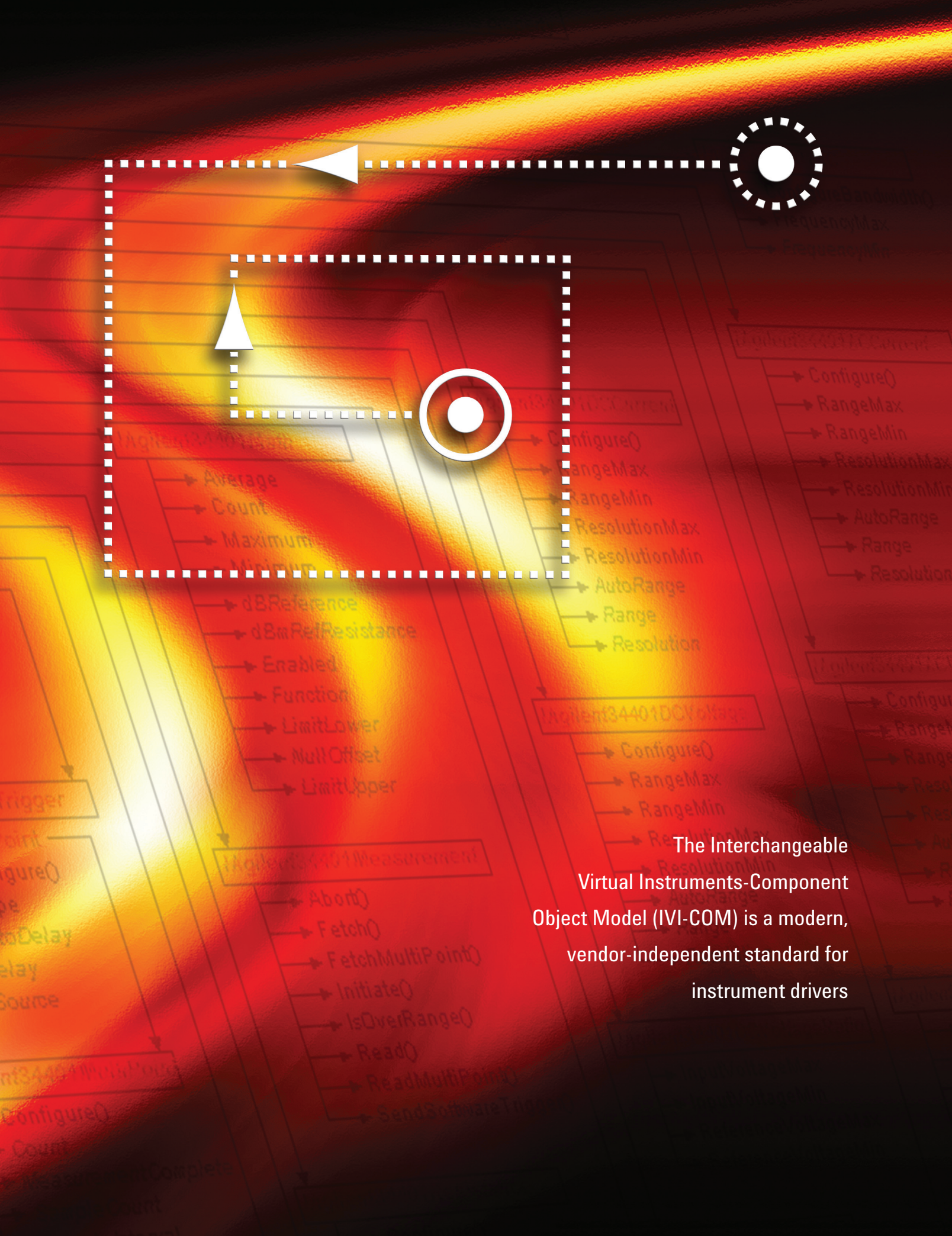

The Interchangeable Virtual Instruments-Component Object Model (IVI-COM) is a modern, vendor-independent standard for instrument drivers

T

Thanks to a recent recommendation from the LXI Consortium, IVI-COM is garnering more industry-wide attention than ever before. While some in the industry claim that Microsoft COM[®] software is awkward and hard to use, it does have a number of compelling features. Here are the top ten things you should know about IVI-COM.

1. One size fits all

When Microsoft first introduced the COM in 1995, it was developed to fix a number of problems with Dynamic Link Libraries (DLLs). One such issue stems from the fact that DLLs are often very different, with aspects such as data types, function naming, calling convention, and error handling left up to the individual programmer or programming environment. This degree of flexibility can become an issue if you are an application designer and need to make software modules talk to one another. In this case, you might need to adapt your application code to each individual DLL, especially if they were written in different programming environments. In the worst case you would need to create additional glueware for communication between existing modules.

COM changes the equation by removing some of the flexibility. It features a language-independent definition of data

types, naming and calling convention, and error handling, as well as a documentation standard. As a result of this flexibility and because it is the enabling technology behind Object Linking and Embedding (OLE)/ActiveX, COM became very popular in the late 1990s. Driven by this popularity, it is supported today by literally every programming environment available and COM-based drivers are compatible with all modern programming languages. In other words, one size does fit all.

Why should you care about compatibility with all languages, as long as you

get an instrument driver for your chosen language? The answer is simple: because instrument manufacturers can then put all their effort and energy into the development of a single instrument driver. Doing so will yield more comprehensive drivers of higher quality.

Consider, for example, the Visual BASIC[®] code in Figure 1. It shows how to do a basic DC voltage measurement using the IVI-COM driver for the Agilent 34410A Digital Multimeter (DMM). Note that in all programming examples in this article, handling has been omitted for clarity.

```
Dim MyDMM As Agilent34410 ' Declare object variable
MyDMM = New Agilent34410 ' Create object
MyDMM.Initialize("GPIB0::22::INSTR", False, False) ' Initialize instrument session
MyDMM.Utility.Reset() ' Reset instrument
MyDMM.System.WaitForOperationComplete(2000) ' Wait for completion
' Do a DC voltage measurement
Dim Result As Double
Result = MyDMM.Voltage.DCVoltage.Measure(1.0,
    Agilent34410ResolutionEnum.Agilent34410ResolutionDefault)
' Display result
MsgBox("Value: " & Result)
' Close instrument session
MyDMM.Close()
```

Figure 1. Example of a basic DC voltage measurement using the IVI-COM driver for the Agilent 34410A digital multimeter.

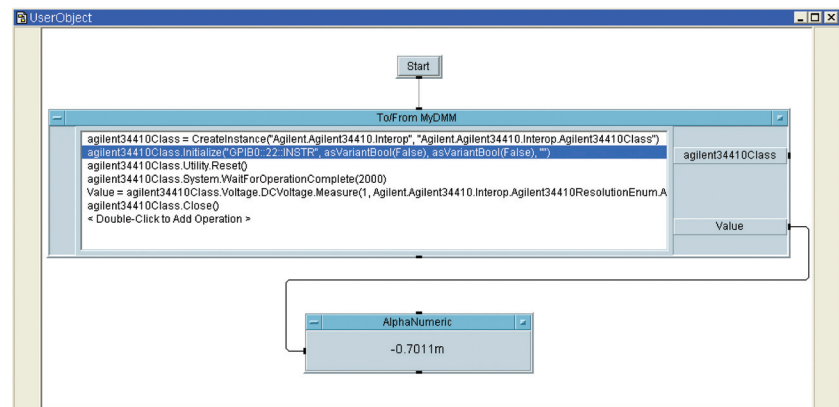

Figure 2. Agilent's VEE

Not surprisingly, the same functionality implemented in Agilent VEE, looks very similar (see Figure 2). You could also call IVI-COM drivers from NI LabVIEW™ and LabWindows/CVI; an ANSI-C (not object-oriented) environment. The example for CVI is shown in Figure 3.

2. Object orientation

Object-oriented programming (OOP) became popular in the 1990s. In OOP, the functionality of a software module is arranged around the real-world objects that the application deals with, such as orders, employees, printers, or multimeters. The objects contain variables describing the

object's state and other relevant attributes and functions that manipulate the data. In OOP terminology, the functions and variables are termed methods and properties, respectively.

OOP is very powerful due to concepts such as object inheritance. Here a new class of objects is derived from an existing one and inherits the methods and properties of that class. The new class can override selected methods with a custom implementation if appropriate.

All modern programming languages support object-oriented programming. There is general consensus that object-oriented

software is easier to modify and maintain than old style software, especially if a team of programmers is involved.

By design, all COM software is object-oriented. Modern programming environments are geared to OOP and handle IVI-COM drivers just like a native class implemented within the environment. Consequently, you can use built-in programming aids and tools when dealing with the driver. Visual Studio®, for example, allows you to inspect the driver using its object browser (see Figure 4).

```
static CAObjHandle MyDMM,MyDMMUtility,MyDMMSystem,
MyDMMVoltage,MyDMMDCVoltage;
double Result;
char s[100];
// Create driver object
Agilent34410Lib_NewIAgilent34410 (NULL, 1, LOCALE_NEUTRAL, 0, &MyDMM);
// Read interface pointers
Agilent34410Lib_IAgilent34410GetUtility (MyDMM, NULL,
&MyDMMUtility);
Agilent34410Lib_IAgilent34410GetSystem (MyDMM, NULL,
&MyDMMSystem);
Agilent34410Lib_IAgilent34410GetVoltage (MyDMM, NULL,
&MyDMMVoltage);
Agilent34410Lib_IAgilent34410VoltageGetDCVoltage (MyDMMVoltage, NULL, &MyDMMDCVoltage);
// Initialize instrument session
Agilent34410Lib_IAgilent34410Initialize (MyDMM, NULL, "GPIB0::22::INSTR", VFALSE, VFALSE, "");
// Reset instrument
Agilent34410Lib_IIVIUtilityReset (MyDMMUtility, NULL);
// Wait for completion
Agilent34410Lib_IAgilent34410SystemWaitForOperationComplete
(MyDMMSystem, NULL, 2000);
// Do a DC voltage measurement
Agilent34410Lib_IAgilent34410DCVoltageMeasure
(MyDMMDCVoltage, NULL, 1.0,Agilent34410LibConst_Agilent34410ResolutionDefault,&Result);
sprintf(s,"%f",Result);
MessagePopup ("Result", s);
// Close instrument session
Agilent34410Lib_IAgilent34410Close (MyDMM);
```

Figure 3. Example of CVI.

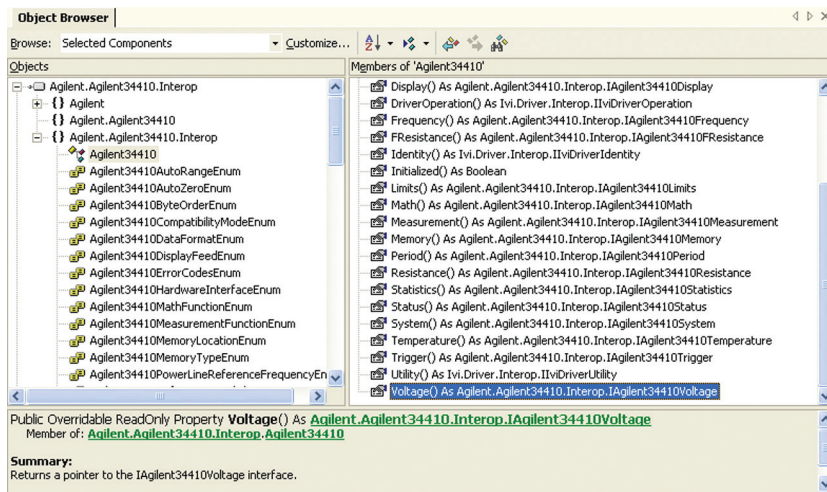

Figure 4. The 34410A IVI-COM driver, as shown in Visual Studio's object browser.

Note that your application does not need to be designed as object-oriented in order to use IVI-COM drivers. You can adopt the classic, procedural approach to programming and still get the benefits of IVI-COM.

3. Structure

Many types of instrument drivers are based on DLLs and contain a flat list of functions such as VXIplug&play¹. The problem with such drivers is that there is no inherent structure in the driver that helps you identify the function you need and the names are often not descriptive due to their limited length.

COM uses interfaces to group related functionality in a module. In an IVI-COM driver, for example, all methods and properties related to triggering would probably be found in a single interface, named ITrigger (by convention, interface names have a leading I in their name). This logical grouping makes it much easier to become familiar with the driver.

IVI-COM drivers go a step further. As shown in Figure 5, they arrange the interfaces in a tree or network structure. Initially, when creating the driver object, a pointer to the

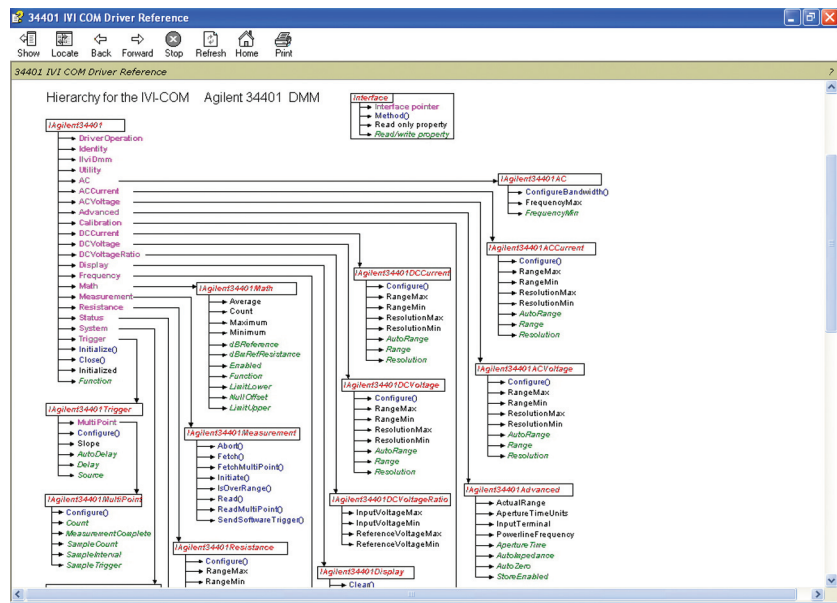

Figure 5. The tree structure of the 34401A IVI-COM driver as documented in the driver's help file.

default interface (in this example, Agilent 34401) will be returned. This top-level interface typically contains a few elementary methods and many so-called pointer properties which reference other interfaces. By reading a pointer property and dereferencing the pointer, you get access to the methods and properties in that other interface.

In Visual BASIC, VEE, and other languages, you can elegantly navigate the driver's network of interfaces and methods using the dot operator, such as DMM.Utility.Reset(). This is illustrated in the code examples previously detailed.

1. The function panels that are part of VXIplug&play enable a tree display of the functions in the driver DLL. However, function panels are an artificial, proprietary add-on to the driver DLL, defined by the VXIplug&play Alliance. Only measurement languages like Agilent VEE are capable of interpreting these files.

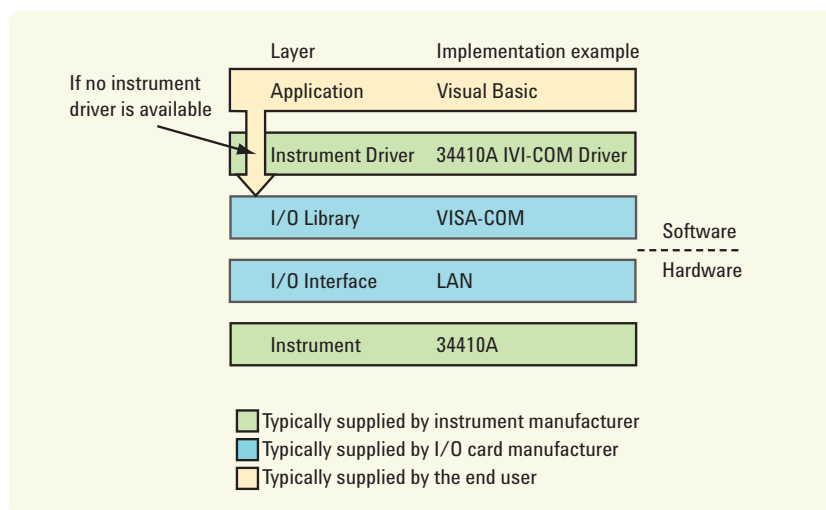

Figure 6. The five layers of test applications.

4. Independence of I/O interface

Like VXIplug&play drivers, IVI drivers are based on the industry standard VISA I/O library as shown in Figure 6. To a certain extent, VISA is just an implementation detail. It remains under the hood, hidden from the application programmer who calls the driver functions. Nevertheless, VISA is a key element because it provides a consistent programming interface for various I/O interfaces, including LAN, USB, GPIB, VXI, and RS232.

Many modern instruments feature alternative I/O interfaces. For example, USB is perfect for ad hoc test automation in a lab environment, whereas LAN is usually the best choice for test systems. Through VISA, support for these different interfaces within the instrument driver comes practically for free. To use a different interface, all you need to do is supply a different VISA address string to the driver's initialize method. Table 1 shows some examples of VISA resource strings.

5. Exchangeability and portability

One of IVI's goals is a higher degree of standardization on the instrument driver layer. IVI's predecessor, the VXIplug&play standard, had only a moderate degree of standardization on this layer which specified such low-level aspects as data types and error handling. IVI, however, goes a

Table 1. VISA resource strings

VISA address string	Description
GPIB0::17::INSTR	GPIB instrument at address 17
TCPIP0::134.40.173.138::INSTR	LAN instrument / "VXI-11" protocol
TCPIP0::134.40.173.138::SOCKET	LAN instrument / TCP socket connection

step further and specifies the exact function prototypes (such as function names and parameters) to be implemented by the driver. Of course, functions and parameters depend on the capability of the instrument. Consequently, various instrument classes were defined by the IVI Foundation, including those for power supplies, oscilloscopes, switches, DMMs, and spectrum analyzers.

By standardizing the driver functions in each class, the application software is isolated from the details of the individual instrument. As a result, a DMM can be exchanged by another without modifying the application's code. Similarly, the same application software can run on several test systems even if the hardware setup is somewhat different.

Admittedly, it is difficult — if not impossible — to achieve complete exchangeability of hardware without any software modifications. That is because many instruments have unique features that are only accessible through non-standard functions. Still, IVI can help minimize the software changes that result from a change in hardware.

The code example in Figure 7 is similar to the ones detailed in Figures 1 and 3. However, this time, IVI class-compliant methods are used. As a result, this code could be used unmodified with other DMMs, as long as they come with an IVI-COM driver.

The only instrument-specific element in Figure 7 is the definition and creation of the driver class, Agilent 34410. If you want truly portable code, you cannot use the class name directly. Instead, as illustrated in the Figure 8, you must use IVI's Session

Factory. This service will accept a symbolic (portable) name, retrieve the corresponding driver class out of a configuration database, and create the driver object.

```
Dim MyDMM As New Agilent34410 ' Declare object variable and create object
Dim MyIvIDMM As IIVIvDmm ' Declare variable for IVI DMM class interface
MyIvIDMM = MyDMM ' Retrieve IVI DMM class interface for MyDMM object
' Now use methods in IVI DMM class interface
MyIvIDMM.Initialize("GPIB0::22::INSTR", False, False)
MyIvIDMM.Utility.Reset()
MyIvIDMM.Function = IIVIvDmmFunctionEnum.IvIDmmFunctionDCVolts
Dim Result As Double
Result = MyIvIDMM.Measurement.Read(2000)
MsgBox("Value: " & Result)
' Close instrument session
MyIvIDMM.Close()
```

Figure 7. Definition and creation of the driver class, 34410.

```
Dim Factory As New IviSessionFactory ' Create object for IVI Session Factory
Dim MyIvIDMM As IIVIvDmm ' Declare variable for IVI DMM class interface
Set MyIvIDMM = Factory.CreateDriver("MyDMM") ' Let session factory create driver object
MyIvIDMM.Initialize("MyDMM", False, False) ' Use symbolic name instead of address string
MyIvIDMM.Utility.Reset()
MyIvIDMM.Function = IIVIvDmmFunctionEnum.IvIDmmFunctionDCVolts
Dim Result As Double
Result = MyIvIDMM.Measurement.Read(2000)
MsgBox("Value: " & Result)
MyIvIDMM.Close()
```

Figure 8. Example of IVI's Session Factory.

```
Dim MyDMM As New Agilent34410 ' Declare object variable and create object
MyDMM.Initialize("GPIB0::22::INSTR", False, False) ' Initialize instrument session
MyDMM.Utility.Reset() ' Reset the instrument
MyDMM.System.WaitForOperationComplete(2000) ' Wait for completion
MyDMM.System.IO.WriteString("*IDN?") ' Ask for ID string using SCPI *IDN? command
Dim s As String
s = MyDMM.System.IO.ReadString ' Read instrument's response
MsgBox("ID String: " & s)
MyDMM.Close() ' Close instrument session
```

Figure 9. This example uses SCPI commands sent through the instrument driver to retrieve the instrument's ID string.

6. Performance

COM exists in different versions. One of these, Distributed COM (DCOM), works across Ethernet. It is based on Remote Procedure Calls (RPC), and, yes, it is relatively slow due to the overhead of sending parameters and return values across the network. However, this is not the version of COM that IVI-COM uses. Instead, IVI-COM is based on the DLL version of COM. As mentioned earlier, the DLL needs to adhere to the calling convention, data types, error handling, and so on, that COM specifies. Nevertheless, calling a COM method within a DLL is just as fast as calling any other DLL function. DLLs are loaded into the calling application's address space, and access works efficiently through local function calls.

7. Flexibility

Ideally, instrument drivers cover 100 percent of the instrument's functionality. Sometimes however, they cover less than that — a subset deemed appropriate for automated use of the instrument. What can you do in those rare situations when the capability you require is not available in the driver?

Most IVI-COM drivers feature Standard Commands for Programmable Instrumentation (SCPI) pass-through methods that allow you to send native instrument commands in an orderly manner through the driver. The example in Figure 9 uses SCPI commands sent through the instrument driver to retrieve the instrument's ID string.

8. Versioning

DLLs are often shared between applications. A new application you install on your system might come with a new version of a shared DLL which includes some enhanced or added functionality. Slight changes in the behavior of the updated DLL might cause an older application to stop working properly. Applications might become incompatible simply because they require different versions of the same, shared DLL.

COM works around this issue by allowing several versions of the same functionality to coexist in a single module. Older software continues to use the existing, unmodified functionality. New software, at the same time, can benefit from an updated version of the functionality.

9. Documentation

COM modules include a description of their contents such as classes, interfaces, methods, and properties, in the form of a type library, that is either hidden in the main driver file or as a separate type library file (*.TLB or *.OLB). This electronic documentation contains all of the information that is required to create objects, call methods, and so on. The type library information is read by the programming environment and allows it to facilitate access to the software module in an easy-to-use, elegant manner.

In earlier days before COM, header files were used to specify the functions in a driver, as well as their parameters. However, such header files depend on the programming language, and they do not contain nearly as much information as a COM type library.

Type libraries are in binary format. If you want to inspect them out of curiosity, Microsoft offers the OLE/COM Object Viewer tool for that specific purpose. It comes with Visual Studio (run oleview.exe), an example of which is shown in Figure 10. Note that normally it is not necessary to inspect the type library as IVI-COM drivers also come with a Windows® help file for the user.

10. Ease of use

Applications using regular DLLs can be fragile and very sensitive to changes in DLL location. Usually, the location has to be part of the Windows search path for Windows to be able to find and load the modules. Changes in the current directory or the Windows search path variables can cause trouble.

Unlike regular DLLs, COM modules are usually registered in the system registry by their installation routines. Applications and Windows itself can then search the registry to find details about a given module's installation. For example, when an application asks Windows to load a COM module, Windows is able to retrieve the exact location of the driver DLL through the registry.

This ease-of-use becomes very apparent when referencing a driver, or asking the programming environment to load and digest the contents of a type library. The programming environment compiles a list of installed drivers based on the entries in the system registry. You can then pick the proper library based on the module's descriptive name. Figure 11 shows a list of COM modules offered by Visual Studio.

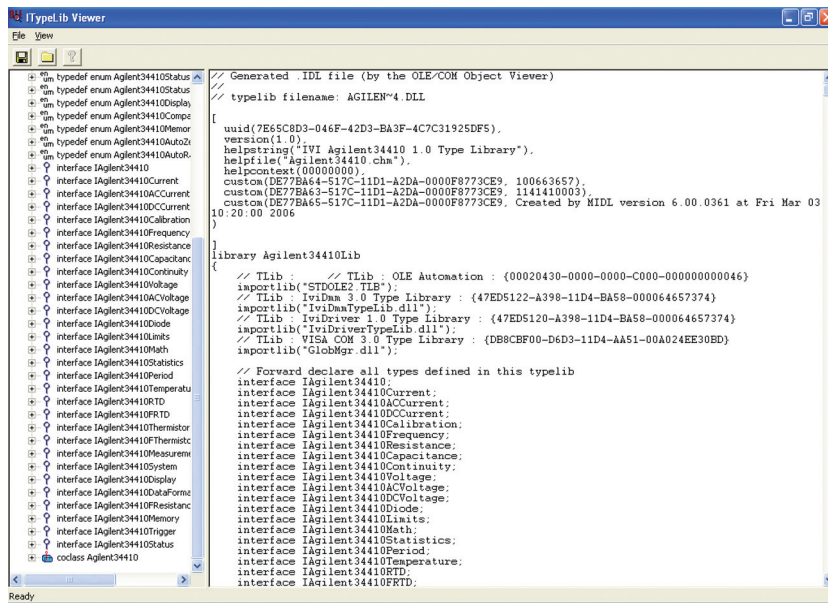

Figure 10. The 34410A IVI-COM driver is shown here in the OLE/COM object viewer.

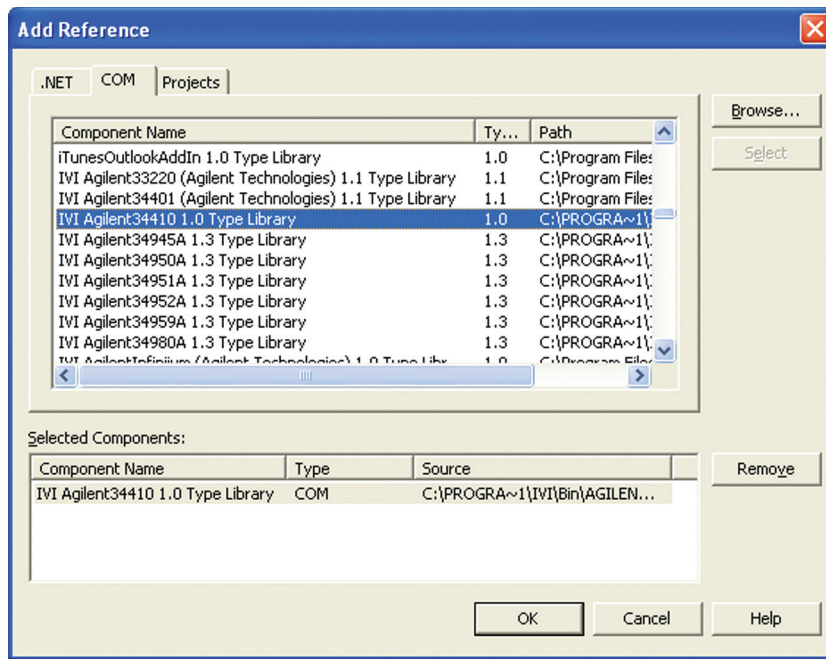

Figure 11. Installed COM software, as displayed by Visual Studio.

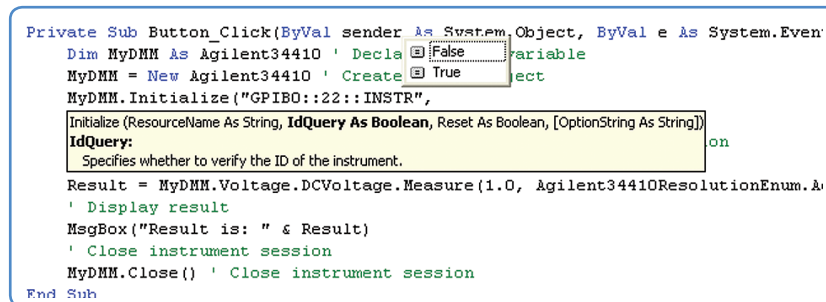

Figure 12. Microsoft IntelliSense at work.

Another helpful feature in Visual Studio is IntelliSense for code insight and completion. This is especially powerful with IVI-COM drivers because it handles interface pointers and thereby allows you to navigate the driver's network of methods (see Figure 12).

Conclusion

IVI-COM clearly has a number of advantages over older instrument driver standards. The most important one by far is the fact that these drivers work with literally every modern programming language. Most languages handle the driver like a native class, and integration is seamless. As a result, once you get the hang of it, these drivers can be both effective and fun to use.

LabView and LabWindows/CVI are trademarks of National Instruments.

Microsoft is a U.S. registered trademark of Microsoft Corporation.

Microsoft COM, Visual Studio, and Visual BASIC are trademarks of Microsoft Corporation in the United States and/or other countries.

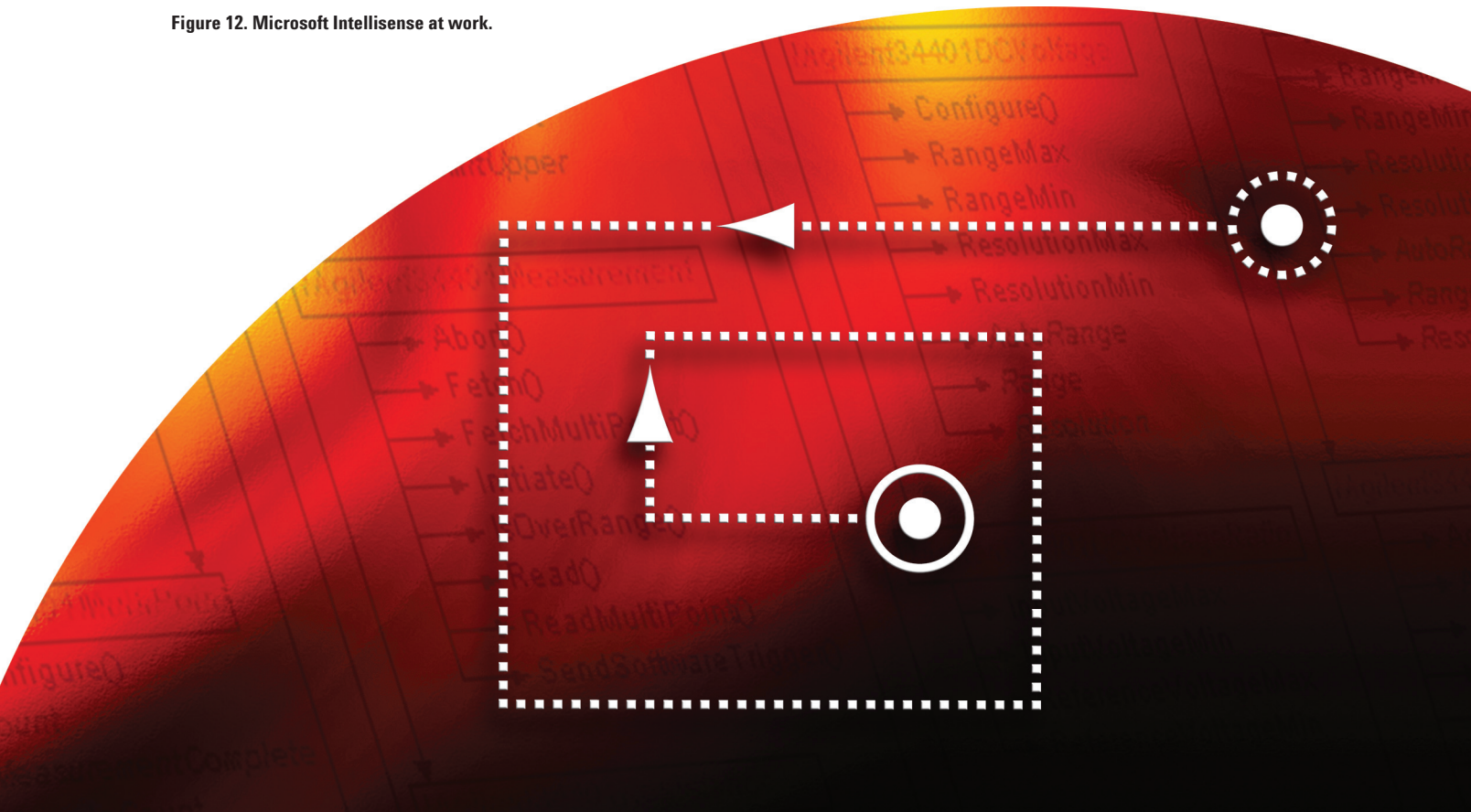

Agilent Labs Awards Innovation Prize



The Barney Oliver Prize honors
innovative technical contributions to Agilent

Mary Lou Simmermacher

*Technology Communications Manager,
Agilent Laboratories, Agilent Technologies*
marylou_simmermacher@agilent.com

Agilent Laboratories recently awarded the 2006 Barney Oliver Prize for Innovation to retired Agilent Fellow Nick Moll. The prize recognizes outstanding technical contributions at Agilent Laboratories that demonstrate creativity, innovation, technical depth, synergy, and business value that lead to a useful technical or scientific result.

Nick's pioneering work translated advanced compound semiconductor device concepts into a leading-edge, indium phosphide (InP) hetero-structure bipolar transistor (HBT) process for integrated circuits (ICs). Agilent uses this state-of-the-art technology to manufacture ICs for its test-and-measurement instruments. Customers directly benefit from this technology because many Agilent instruments take advantage of the design efficiency, increased performance and reliability, lower cost, and advanced features provided by this remarkable technology.

"It's a great pleasure for Agilent Laboratories to honor Nick Moll with the 2006 Barney Oliver Prize for Innovation," said Darlene Solomon, Agilent chief technology officer and vice president of Agilent Laboratories. "The pioneering contributions of Nick and his colleagues in advanced compound semiconductor device technology are a compelling demonstration of how Labs researchers create business and customer value through world-class technology innovation."



Figure 1. Nick Moll receives the 2006 Barney Oliver Prize for Innovation from Agilent Chief Technology Officer and Vice President of Agilent Laboratories, Darlene J.S. Solomon.

Nick's research

In the 1990s Nick was not satisfied with the performance of the HBT technology Agilent was using in many instruments — even though he had developed it in the 1980s in partnership with the Agilent Santa Rosa Technology Center, which specializes in customized, high-performance semiconductor technology (see *Agilent Inside: Agilent's Advanced High-Frequency IC Technology* in this issue).

"The performance of gallium arsenide HBT technology was good, but it wasn't going to get much better," said Nick. "I was looking around for some sort of technology for ICs that would make a really big difference in a variety of ways and improve performance by at least a factor of two."

Nick and his team began work using indium phosphide (InP) for the next generation of HBT technology. Shortly after they started, Colombo Bolognesi, a professor Nick knew at Simon Fraser University in Canada, made an unexpected advance in a related material technology using gallium arsenide antimonide lattice-matched to InP as a base material. Nick was excited because it seemed like it would solve some lingering issues his team had with InP, and the two teams collaborated to accelerate development.

"This was completely unproven technology," said Nick. "No one else was working on it in a serious way. I wanted to get it into the hands of the people at the Technology Center quickly and work with them because I thought it would make a difference for Agilent."

The results

Now in production, the next-generation HBT IC technology enables better noise performance, higher frequency instruments, mixed-signal capability, more output power, lower cost, and roughly three times the performance of previous HBT technology.

"Nick's fundamental contributions and long-standing working relationship with my team have helped enable several billion dollars in revenue for Agilent's test and measurement business," said Jerry Gladstone, retired vice president and general manager of the Agilent Santa Rosa Technology Center.

"This project looks like a big investment to make," said Don D'Avanzo, new technology introduction and materials manager at the Agilent Santa Rosa Technology Center. "But when you look at the benefits, it certainly pays off over and over again. This is only one component in an instrument, but it's key to keeping Agilent competitive."

Nick's contributions

Nick's vision, technical knowledge, innovation, and teamwork span a wide range of technologies, disciplines, and organizations.

Vision

Nick envisioned and clearly articulated the benefits of adding InP HBT to the company's processing capabilities. His vision inspires people who work with him.

"Nick was far ahead of the business need by as much as 10 years in some cases," said Derry Hornbuckle, who was R&D manager of the Agilent Santa Rosa Technology Center during the development. "Without Nick's contributions, a lot of our work wouldn't have happened. We would have had to look outside the company for components, the same ones our competitors are using."

Technical knowledge

Nick is widely recognized in the international compound semiconductor community, has published more than 30 papers, contributed invited chapters to several books, and served as editor of the *IEEE Transactions on Electron Devices* from 1990 to 1996.

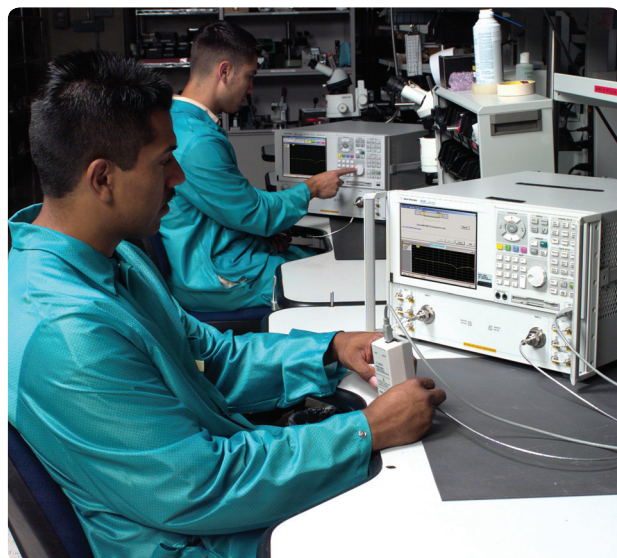

Figure 2. The Agilent N5230A 50 GHz precision network analyzer, which contains the InP HBT technology, enables microwave engineers to characterize components faster and increase production throughput while enhancing accuracy.

"Nick consistently demonstrated technical expertise, depth, and leadership that spanned the entire range of our collective fields of expertise," wrote his team members in the award nomination. "Whenever we had a technical problem for which we wanted some help, we nearly always turned to Nick, and having gone to Nick, there was usually no reason to go further."

"Nick's understanding of device physics and how transistors work is second to none," said Derry. "With his involvement in a number of projects over the years, it's hard to think of anyone else who could compare. The level of his contributions to the Technology Center — those that ended up in customers' hands — are second to none."

Innovation

Nick was one of the first to recognize the opportunity presented by a novel materials combination under investigation in Professor Colombo Bolognesi's group at Simon Fraser University. Nick engaged with this group early on and nurtured their progress with external research grants and a consulting arrangement with Professor Bolognesi.

Nick spearheaded all aspects of the Labs effort, including innovations in materials growth development, a device fabrication process for manufacturability, and a predictive device simulation capability that shortened device design cycles and time to production.

Teamwork

"We had an extensive partnership," said Don. "Nick and his team joined our monthly meetings by telephone, visits, and online meetings. We'd shift locations and also go to the Labs. Nick appreciates and champions the requirements of a manufacturing environment, such as low cost, yield, and reliability. He enhanced our partnership and felt he wouldn't be successful until we got this technology released to manufacturing."

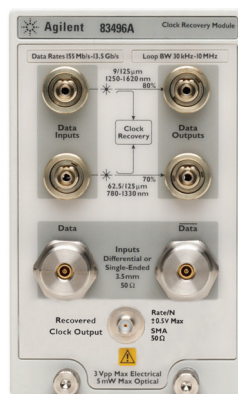

Figure 3. A key circuit in Agilent's 83496A multi-rate optical/electrical clock recovery module was designed in the InP HBT process. This is the industry's first clock recovery module with the necessary sensitivity and accuracy for high-speed waveform analysis at any data rate.

There was a long period of time when the Labs and the Technology Center were working simultaneously on the technology, and Nick enabled team members to give their best to the project. "Nick accepts our ideas, our problems, and even our errors with serious, thoughtful attention, with constructive guidance, and without being judgmental. Consequently, we feel free to take risks with Nick, to bring Nick our crazy ideas, and to seek Nick's counsel."

"Over the course of my career, I've become convinced that teamwork is a huge element of real project success," said Nick, "especially when I think of what Agilent Labs has been able to accomplish in regard to HBTs. We were able to make great strides due to the strong and collaborative partnerships we have with Agilent organizations such as the Technology Center."

"So I want to acknowledge that there are dozens and dozens of people who made big contributions to this work and who deserve a lot of credit, not just me. But it's fair to say that I'm tickled pink about getting the award."

"This was one of the most exciting projects I've ever done," said Nick. "We were able to take the whole thing from the beginning, use very unconventional technology, and get it into production very quickly with a lot of tools we had never used before."

About the Barney Oliver Prize

The Barney Oliver Prize for Innovation honors Bernard M. Oliver (1916 to 1995), who was a scientist, inventor, and innovator. Agilent Laboratories has awarded the prize annually since 1999 for contributions to Agilent that result from work done in the Labs and that demonstrate Barney's outstanding qualities of creativity, innovation, technical depth, breadth of expertise, and respect for business value. The prize consists of \$10,000 after-tax cash and a bronze statue.

Dr. Oliver, known to all as Barney, was a man of enormous intellect, curiosity and vision. When he was 19, he graduated from Stanford University with a B.A. in electrical engineering. A year later he completed an M.S. from the California Institute of Technology, where he earned a Ph.D., graduating magna cum laude at the age of 24.

Barney then joined Bell Telephone Laboratories where he quickly established a reputation for brilliant, creative insights and clever inventions. In 1952, Bill Hewlett and David Packard persuaded Barney, whom they had known since their student days, to join their fledgling operation as director of research. In 1957 he became vice president of Research and Development, and in 1966, he established Hewlett-Packard Laboratories, which he directed until his retirement in 1981.

During his career Barney was awarded 60 patents and authored 71 papers that reflect a remarkable breadth and depth of thought, ideas, and actions spanning physics, mathematics, electronic and electrical engineering, education, and social issues. He was active in the IEEE and served as its president in 1965.

Barney had a lifelong interest in astronomy, and in particular the use of radio telescopes for the search for extraterrestrial intelligence. Between 1982 and 1993 he was the chief engineer of the SETI (Search for Extraterrestrial Intelligence) Institute and member of the SETI board of trustees.

Barney received many awards. In 1986 U.S. President Reagan awarded Barney the National Medal of Science for "translating the most profound discoveries of physical and communication science into the electronic, radio, and computer systems which have improved our culture and enriched the lives of all Americans." In 1997 the SETI Institute established the Bernard M. Oliver Chair, and in 2004 Barney was inducted posthumously into the National Inventors Hall of Fame. Among his academic honors were the Halley Lectureship on Astronomy and Terrestrial Magnetism of Oxford University (1984).

Contact Agilent

Online resources

- Locate product and support information with simple navigation to technical overviews, manuals, news releases, education course descriptions and schedules, and much more
- Access customer support services
- Find information on recommended replacements for discontinued products
- Place an order or check your order status in the Agilent Direct Online Store
- Subscribe to Agilent's free email update service to stay current on the latest Agilent product, support, and application information — customized for your interests and preferences

Agilent Direct store features

- Quickly build and place your order, 24x7
- Easily select and configure your products
- Share carts within your company (e.g. technical team and purchasing)
- Flexible payment options
- Secure transactions
- Order basic instruments, general purpose test accessories, and microwave test accessories online today (available to U.S. customers only)



www.agilent.com/find/contactus

www.agilent.com/find/onlinestore

View products available through the online store - [Agilent Direct Store Catalog](#)

Locate and purchase replacement parts or hardcopy manuals for your Agilent product - [Find a Manual](#)

Registered users - access your shopping carts and profile. [Agilent Direct login.](#)

Order Status: Up-to-date information about your orders for parts and products, even if you are not a registered user. This information includes:

- Order Status
- Estimated shipment date
- Link to shipper - for tracking shipment status
- Available to customers in the Americas, Europe, and Japan

Registered users - view your order status. [Agilent Direct login.](#)

It only takes a moment to sign up for Agilent Direct Order Status & Online Store - [Register](#)

34401A Digital Multimeter, 6 1/2 Digit

Add to Cart Price (United States): from **US\$ 1,172**. Usually ships in: **1 week(s)**. This information is subject to change without notice. Use the Select a Country link above to change country setting.

[How to Buy](#) · [Get a Quick Quote in 2 min.](#) · [Calibration or Repair Quote](#) · [Side-by-Side Comparison](#)

Agilent has just introduced two new 6 1/2 digit digital multimeters. The NEW 34410A and 34411A have significantly enhanced functionality for bench and system users.

- Compare the 34401A digital multimeter to the new 34410A and 34411A.
- Trade up to the next-generation digital multimeters for the 34401A price!

The Agilent 34401A multimeter is a tool kit of useful testing functions. In addition to the standard functions you've come to expect from a high quality digital multimeter, you also get many other capabilities, from min/max/avg to built-in limit testing. 6 1/2 digit precision measurements for an affordable price means you can make measurements with confidence without breaking your budget.

Features

- 6 1/2 digit resolution
- 0.0035% 1 year dcV accuracy, 0.06% 1 year acV accuracy
- Twelve measurement functions, plus limit testing and min/max/average
- True RMS AC volts and current
- 1000 readings/second in ASCII format across the GPIB bus
- RS-232 and GPIB Standard, [USB optional](#)
- For complete details, click on the Data Sheet link

Key Library Information

- [Technical Support](#) - Manuals, Drivers & Software, Application Notes, FAQs ...
- [Library](#) - Specifications, Selection & Configuration Guides, Brochures, Demos ...

Data Sheet: Agilent 34401A Multimeter - Uncompromising Performance for Benchtop and System Testing	2006-10-05	130 KB	order a copy
Reference Guide: 34401A Standard Shipped Components	2002-09-20		
Software Release: IntuiLink for DMM 34401A, 34405A, 34410A, 34411A, 34420A Multimeters, Version 1.3.1	2006-07-21		

Other Links

- [Order Status](#)
- [Parts](#)

Highlights

- [Make your migration smooth when moving to the new Agilent 34410A or 34411A DMMs](#)
- [Take full advantage of the new features and higher performance of the new models. Download now.](#)
- [New digital multimeters, 6 1/2 digit](#)
- [Learn more about the next generation digital multimeter, trade up for a 26% credit, and call a live engineer to meet your needs.](#)
- [Front Agilent 2006 Basic Instruments CDI](#)
- [New version includes new products, catalogs, data sheets, demos and application](#)

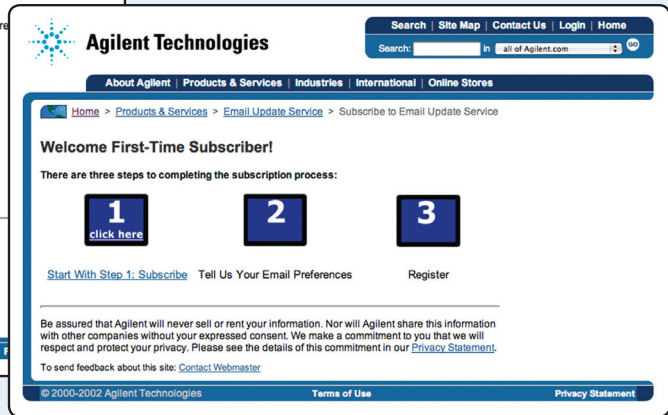
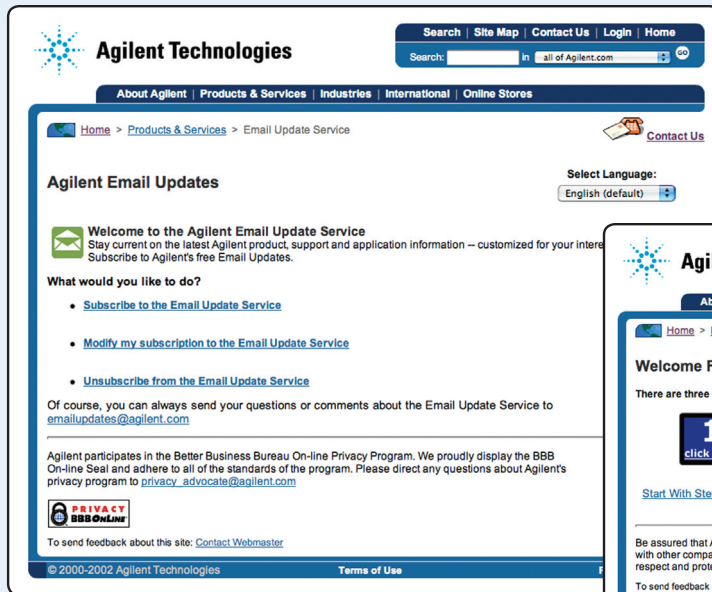

Free Email Update Service

Get the latest information and newest test skills

Subscribe to Agilent's free Email Update Service for the latest Agilent product, support and application information — customized for your interests and preferences.

Only the information you want, when you want it

Easily identify your specific interests from a selection of more than 100 product and application areas and specify the types of information you would like to receive:

- **Support information** (such as new products and enhancements information/specifications, application information and technical notes on technologies and standards, tradeshow, events, and live/virtual seminars)
- **What's New** (including education/training and consulting services, firmware/software upgrades, and warranty, calibration and repair)

Total commitment to privacy

Agilent is proud to participate in the Better Business Bureau On-Line Privacy Program, and we adhere to all of the program's standards. We will never sell or rent your email address, nor will we share it with anyone without your consent. If you have any questions, please contact our privacy advocate via email at privacy_advocate@agilent.com

 **Agilent Email Updates**
www.agilent.com/find/emailupdates

Get the latest information on the products and applications you select.

A new standard is open — see it realized with Agilent Open

Agilent Open simplifies the process of connecting and programming test systems to help engineers design, validate and manufacture electronic products. Agilent offers open connectivity for a broad range of system-ready instruments, open industry software, PC-standard I/O and global support, which are combined to more easily integrate test system development.

LAN eXtensions for Instrumentation (LXI) is the test-system architecture that's based on proven, widely used standards such as Ethernet. LXI enables fast, efficient and cost-effective creation — and reconfiguration — of test systems.

With the added leverage of Agilent Open, you can accelerate the integration of systems that include LXI devices and your existing test assets. Through these powerful tools, Agilent can help you and your team open new possibilities in testing.

Agilent Open 
www.agilent.com/find/open

LXI 
www.agilent.com/find/lxi

Leasing May Be the Answer

If you have not considered leasing, now is the time

Monica Braley

*Sales Development, Customer Financing
Agilent Technologies
monica_braley@agilent.com*

Agilent has teamed with GE Capital Solutions to bring you the most innovative equipment coupled with a financing solution designed to meet your specific needs. Through this partnership, we are focused on providing both the equipment and the financial products that help drive your business, so you can upgrade your technology more easily, match payments to usage, and maintain flexibility as your needs change.

Consider this scenario: "Our test equipment was six years old and it was obsolete for the products we needed to develop. Calibration, maintenance, and service were not only financially burdensome but the resulting downtime was negatively affecting our manufacturing and test productivity. We turned to Agilent to replace our older instruments with new Agilent technology."

"We originally thought we had to pay cash for the new equipment but our GE Capital Solutions representative showed us how we could use financing and put our cash to work in better ways. GE Capital Solutions worked with us to show us how the flexibility of bundled financing, multi-year maintenance, and software updates could provide us with the opportunity to upgrade or refresh our test equipment every three years — all for a low monthly payment that we could easily afford."

The benefits of leasing

Consider this:

- Lease payments are predictable and affordable — payments may be structured to meet your needs, to manage your cash flow.
- Leasing offers customized payment structures — options such as deferred payments, matching payments to your usage, or matching the lease term to the length of your project. A variety of end-of-lease options are available as well, such as renewal, purchase, or return.
- Leasing creates an obsolescence hedge — it gives you the flexibility to migrate to the latest technology when you need it.
- Leasing is a single source for all your needs — your entire acquisition of equipment, maintenance, software, and implementation may be simplified into one easy, monthly payment.
- Leasing preserves working capital — without the large capital outlay of a purchase, cash may be strategically re-invested into your business. Credit lines may be saved for other operating needs.
- Leasing facilitates easy upgrades — it gives you the flexibility to upgrade and add on as your business grows. It may also allow you to redeploy assets when the need arises.

See for yourself.
Call GE Capital Solutions at
1-866-230-4600
for more information
www.agilent.com/go/leasing

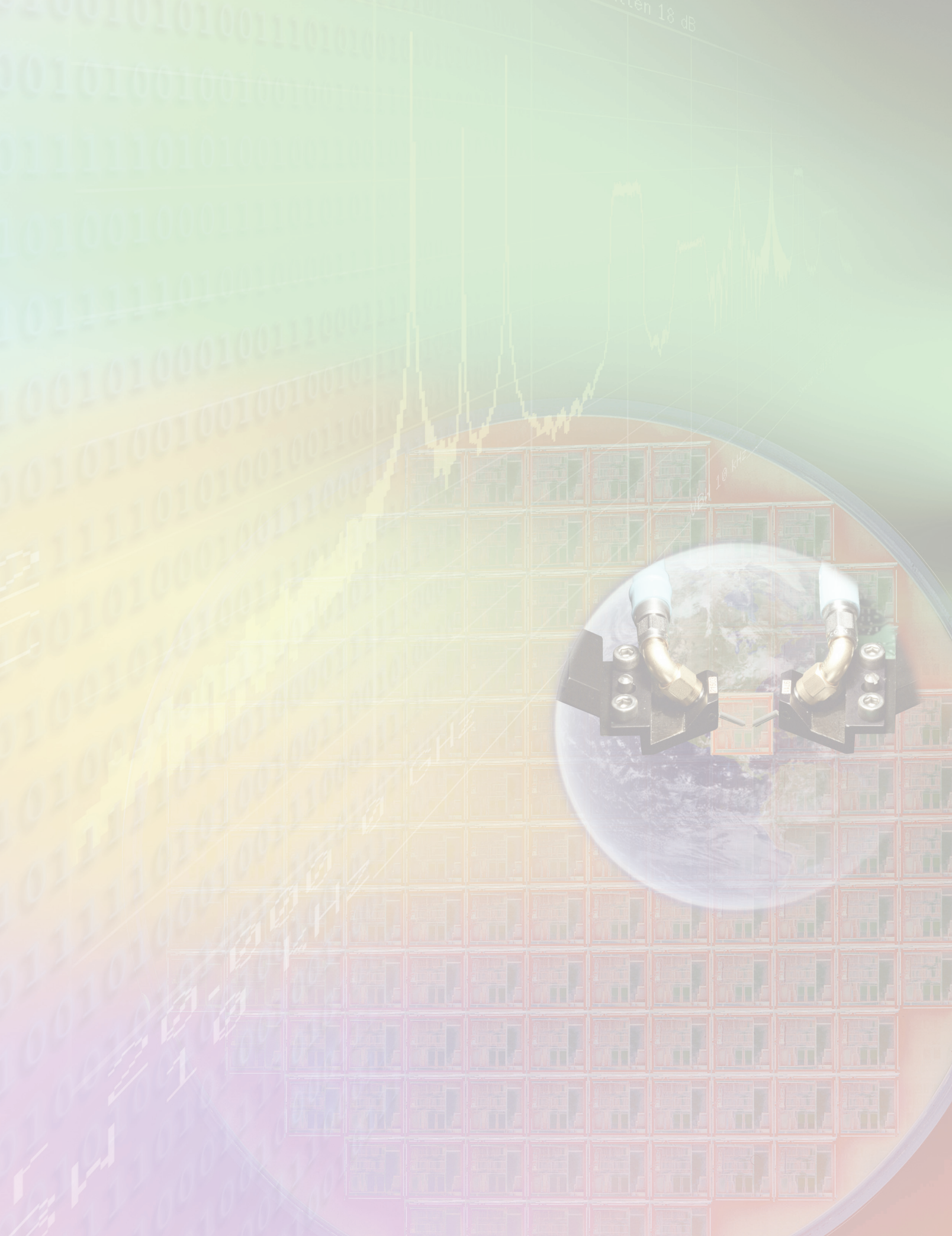



Agilent Technologies

Department DMEP539D701

P.O. Box 3828

Englewood, CO 80155-3828

CHANGE SERVICE REQUESTED